

Owner's Manual

Model No.

16007409000

CT900

- Assembly
- Operation
- Adjustments
- Parts
- Warranty

CAUTION:

Read and understand this manual before operating unit

SPIRIT



**Retain For Future
Reference**

TABLE OF CONTENTS

Product Registration 3

Important Safety Instructions..... 5

Important Electrical Informations 6

Important Operation Instructions7

Assembly Instructions..... 9

Operation of Your New Treadmill.....16

Programmable Features18

Using a Heart Rate Transmitter 27

Exploded View Diagram.....30

Parts List.....31

General Maintenance 34

Service Checklist – Diagnosis Guide 36

Manufacturer’s Limited Warranty 43

Thank you for purchasing our product, please save these instructions. Please do not perform or attempt any customizing, adjustments, repair or maintenance that is not described in this manual.

SPIRIT

***CONGRATULATIONS ON YOUR
NEW TREADMILL AND WELCOME
TO THE SPIRIT FAMILY!***

Thank you for your purchase of this quality treadmill from Dyaco Canada Inc. Your new treadmill was manufactured by one of the leading fitness manufacturers in the world and is backed by one of the most comprehensive warranties available. Through your dealer, Dyaco Canada Inc. will do all we can to make your ownership experience as pleasant as possible for many years to come. The local dealership where you purchased this treadmill is your administrator for all warranty and service needs. Their responsibility is to provide you with the technical knowledge and service personnel to make your experience more informed and any difficulties easier to remedy.

Please take a moment at this time to record the name of the dealer, their telephone number, and the date of purchase below to make any future, needed contact easy. We appreciate your support and we will always remember that you are the reason that we are in business. Please go to www.dyaco.ca/warranty.html and complete the online warranty registration.

Yours in Health,
Dyaco Canada Inc.

Name of Dealer _____
Telephone Number of Dealer _____
Purchase Date _____

Product Registration

RECORD YOUR SERIAL NUMBER

Please record the Serial Number of this fitness product in the space provided below.

Serial Number _____

REGISTER YOUR PURCHASE

Please visit us at www.dyaco.ca/warranty.html to register your purchase.

BEFORE YOU BEGIN

Thank you for choosing the SPIRIT CT900 Treadmill. We take great pride in producing this quality product and hope it will provide many hours of quality exercise to make you feel better, look better, and enjoy life to its fullest. It's a proven fact that a regular exercise program can improve your physical and mental health. Too often, our busy lifestyles limit our time and opportunity to exercise. The SPIRIT CT900 Treadmill provides a convenient and simple method to begin your assault on getting your body in shape and achieving a happier and healthier lifestyle. Before reading further, please review the drawing below and familiarize yourself with the parts that are labeled.

Read this manual carefully before using the SPIRIT CT900 Treadmill. Although Dyaco Canada Inc. constructs its products with the finest materials and uses the highest standards of manufacturing and quality control, there can sometimes be missing parts or incorrectly sized parts. If you have any questions or problems with the parts included with your SPIRIT CT900 Treadmill, please do not return the product. Contact us **FIRST!** If a part is missing or defective call us toll free at 1-888-707-1880. Our Customer Service Staff are available to assist you from 8:30 A.M. to 5:00 P.M. (Eastern Time) Monday through Friday. Be sure to have the name and model number of the product available when you contact us.

IMPORTANT SAFETY INSTRUCTIONS

WARNING - Read all instructions before using this equipment.

DANGER - To reduce the risk of electric shock, always unplug this treadmill from the electrical outlet prior to cleaning and/or service work.

WARNING - To reduce the risk of burns, fire, electric shock, or injury to persons, install the treadmill on a flat level surface with access to a 120-volt, 20-amp grounded outlet.

WARNING - Heart rate monitoring systems may be inaccurate. Over exercising may result in serious injury or death. If you feel faint stop exercising immediately.

DO NOT USE AN EXTENSION CORD UNLESS IT IS 14 AWG OR BETTER, WITH ONLY ONE OUTLET ON THE END. The treadmill should be the only equipment in the circuit in which it is connected. **DO NOT ATTEMPT TO DISABLE THE GROUNDED PLUG BY USING IMPROPER ADAPTERS, OR IN ANY WAY MODIFY THE CORD SET.** A serious shock or fire hazard may result along with computer malfunctions.

- Do not operate treadmill on deeply padded, plush or shag carpet. Damage to both carpet and treadmill may result.
- Keep children under the age of 13 away from the treadmill. There are obvious pinch points and other caution areas that can cause harm.
- Keep hands away from all moving parts.
- Never operate the treadmill if it has a damaged cord or plug. If the treadmill is not working properly, call your dealer.
- Keep the cord away from heated surfaces.
- Do not operate where aerosol spray products are being used or where oxygen is being administered. Sparks from the motor may ignite a highly gaseous environment.
- Never drop or insert any object into any openings.
- Do not use outdoors.
- To disconnect, turn all controls to the off position and then remove the plug from the outlet.
- Do not attempt to use your treadmill for any purpose other than for the purpose it is intended.
- The hand pulse sensors are not medical devices. Various factors, including the user's movement, may affect the accuracy of heart rate readings. The pulse sensors are intended only as exercise aids in determining heart rate trends in general.
- Wear proper shoes. High heels, dress shoes, sandals or bare feet are not suitable for use on your treadmill. Quality athletic shoes are recommended to avoid leg fatigue.
- Children should be supervised to ensure that they do not play with the equipment.
- Remove tether cord after use to prevent unauthorized treadmill operation.
- Connect this treadmill to a properly grounded outlet only. See Grounding Instructions.
- This exercise equipment is not intended for use by persons with reduced physical, sensory or mental capabilities, or lack of experience and knowledge.
- Before beginning this or any exercise program, consult a physician. This is especially important for persons over the age of 35 or persons with pre-existing health conditions.
- Close supervision is necessary when this exercise equipment is used by, on, or near children, invalids, or disabled persons.
- User weight should not exceed 450 lbs (204 kgs).

SAVE THESE INSTRUCTIONS - THINK SAFETY!

IMPORTANT ELECTRICAL INFORMATIONS

WARNING!

NEVER use a RCD - Residual Current Device (U.S. ver.= GFCI) - wall outlet with this treadmill. As with any equipment with a large motor, the RCD/GFCI will trip often. Route the power mains cord away from any moving part of the treadmill including the elevation mechanism and transport wheels.

NEVER remove any cover without first disconnecting AC power. If voltage varies by ten percent (10%) or more, the performance of your treadmill may be affected. **Such conditions are not covered under your warranty.** If you suspect the voltage is low, contact your local power company or a licensed electrician for proper testing.

NEVER expose this treadmill to rain or moisture. This product is **NOT** designed for use outdoors, near a pool or spa, or in any other high humidity environment. The temperature specification is 40 degrees c, and humidity is 95%, non-condensing (no water drops forming on surfaces).

Circuit breakers: Avoid AFCI/GFCI circuit breakers if possible. These breakers may trip occasionally during use because of the high inrush currents from the treadmill drive motor. This condition is an issue with all treadmills and other products with large motors or electric heating elements like ovens. New laws in your area may require these breakers. If you do have these breakers and outlets in your home and are experiencing nuisance tripping, you should check to see if there are any other devices plugged into the same circuit like fluorescent lights with electronic ballasts, coffee maker, space heater, etc. Optimally the treadmill should be the only device plugged into the circuit. Our treadmills have surge suppressors built in to help avoid nuisance tripping. We have tested several AFCI/GFCI breakers and outlets with our products that do not trip when only the treadmill is connected. Brands we have tested are: Eaton (Cutler Hammer Series), Leviton (Smart lock pro) and Schneider Electric (Canadian home series).

GROUNDING INSTRUCTIONS

This product must be grounded. If the treadmill's electrical system should malfunction or breakdown grounding provides a path of least resistance for electric current, reducing the risk of electric shock. This product is equipped with a cord having an equipment-grounding plug. The plug must be plugged into an appropriate outlet that is properly installed and grounded in accordance with all local codes and ordinances.

DANGER - Improper connection of the equipment-grounding conductor can result in a risk of electric shock. Check with a qualified electrician or serviceman if you are in doubt as to whether the product is properly grounded. Do not modify the plug provided with the product if it will not fit the outlet; have a proper outlet installed by a qualified electrician.

IMPORTANT OPERATION INSTRUCTIONS

- **NEVER** operate this treadmill without reading and completely understanding the results of any operational change you request from the computer console.
- Understand that changes in speed and incline do not occur immediately. Set your desired speed on the computer console and release the adjustment key. The computer will obey the command gradually.
- **NEVER** use your treadmill during an electrical storm. Surges may occur that could damage treadmill components.
- Use caution while participating in other activities while walking on your treadmill; such as watching television, reading, etc. These distractions may cause you to lose balance or stray from walking in the center of the belt; which may result in serious injury.
- **NEVER** mount or dismount the treadmill while the belt is moving. Treadmills start with at a very low speed and it is unnecessary to straddle the belt during start up. Simply standing on the belt during slow acceleration is proper after you have learned to operate the unit.
- Always hold on to a handrail or hand bar while making control changes (incline, speed, etc.).
- Do not use excessive pressure on console control keys. They are precision set to function properly with little finger pressure. Pushing harder is not going to make the unit go faster or slower. If you feel the buttons are not functioning properly with normal pressure contact your dealer.

SAFETY TETHER CORD

A safety tether cord is provided with this unit. It is a simple magnetic design that should be used at all times. It is for your safety should you fall or move too far back on the tread-belt. Pulling this safety tether cord will stop tread-belt movement.

To Use:

1. Place the magnet into position on the round metal portion of the console control head. Your treadmill will not start and operate without this. Removing the magnet also secures the treadmill from unauthorized use.
2. Fasten the plastic clip onto your clothing securely to assure good holding power. Note: The magnet has strong enough power to minimize accidental, unexpected stopping. The clip should be attached securely to make certain it does not come off. Be familiar with its function and limitations. The treadmill will stop, depending on speed, with a one to two step coast anytime the magnet is pulled off the console. Use the red Stop/Pause switch in normal operation

WARNING DECAL REPLACEMENT

The decal shown below has been placed on the treadmill. If the decal is missing or illegible, please call our Customer Service Department toll-free at 1-888-707-1880 to order a replacement decal.

⚠ WARNING / AVERTISSEMENT

Model/Modèle#: ~~XXXXXXXXXXXX~~
Serial#/Numéro de série: ~~XXXXXXXXXX~~

**For consumer use.
Max user weight limit**
~~Maximum Weight Limit~~

CAUTION: SMALL CHILDREN AND PERSONS PHYSICALLY HANDICAPPED SHOULD NOT USE ANY EXERCISE EQUIPMENT WITHOUT A QUALIFIED PERSON IN ATTENDANCE.

WARNING: KEEP CHILDREN AWAY FROM THE ~~TREADMILL~~. KEEP BODY AND CLOTHING FREE AND CLEAR OF ALL MOVING PARTS. THE POSSIBILITY OF SERIOUS INJURIES OR DEATH IF CAUTION IS NOT USED. READ ALL WARNINGS AND INSTRUCTIONS PRIOR TO USE. REPLACE LABEL IF DAMAGED, ILLEGIBLE OR REMOVED.

~~NE PAS SE PROSCRIRE~~

**Usage à des fins personnelles
poids maximum de l'utilisateur**
~~Maximum Weight Limit~~

ATTENTION: LES ENFANTS ET LES PERSONNES AYANT UN HANDICAP PHYSIQUE NE DOIVENT UTILISER AUCUN APPAREIL D'EXERCICE SANS LA SURVEILLANCE D'UNE PERSONNE QUALIFIÉE.

AVERTISSEMENT: GARDER LES ENFANTS À L'ÉCART DU ~~TAPPEZ-TOURNEAU~~.

GARDER LE CORPS ET LES VÊTEMENTS ÉLOIGNÉS DE TOUTE PIÈCE MOBILE. LE DÉFAUT DE VIGILANCE DANS L'UTILISATION DE CET APPAREIL POURRAIT ENTRAÎNER DE GRAVES BLESSURES ET MÊME LA MORT. LIRE TOUS LES AVERTISSEMENTS ET TOUTES LES DIRECTIVES AVANT UTILISATION. REMPLACER TOUTE ÉTIQUETTE ENDOMMAGÉE, ILLISIBLE OU MANQUANTE.

~~PROHIBÉ À TOUTES PERSONNES~~

**Dyaco Canada Inc.
5955 Don Murie St
Niagara Falls, ON
L2G 0A9
Customer Service
Service à la clientèle
1-888-707-1880**

ASSEMBLY INSTRUCTIONS

UNPACKING

1. Cut the straps and open box.
2. Locate the hardware package. The hardware is separated into four steps. Remove the tools first. Remove the hardware for each step as needed to avoid confusion. The numbers in the instructions that are in parenthesis (#) are the item number from the assembly drawing for reference.

ASSEMBLY TOOLS

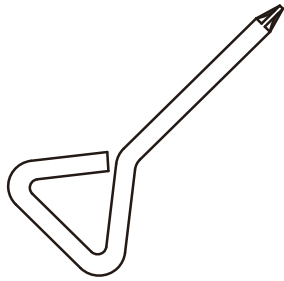

#112. Phillips Head Screwdriver (1 pc)

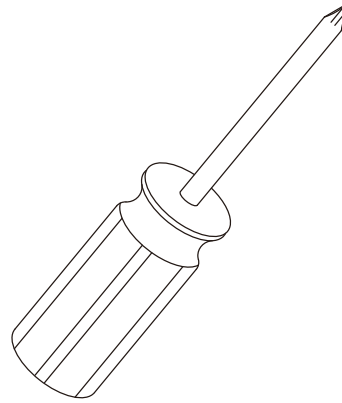

#111. Phillips Head Screwdriver (1 pc)

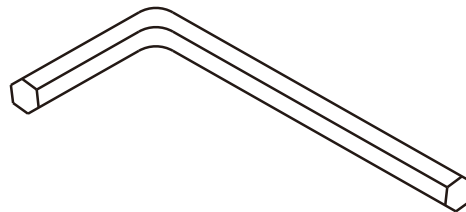

#110. M8 L Allen Wrench (1 pc)

STEP1

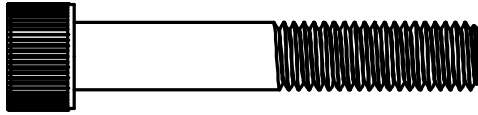

#65 - M10 x 60mm
Socket Head Cap Bolt
(10pcs)

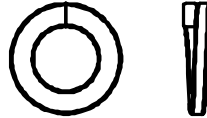

#79 - Ø10 x 2T
Spring Washer
(10pcs)

STEP2

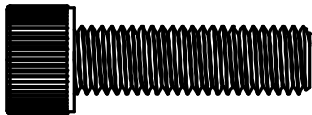

#63 - M10 x 35mm Socket
Head Cap Bolt
(6pcs)

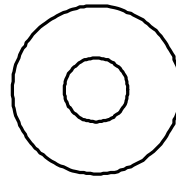

#74 - Ø3/8" x 25 x 3T
Flat Washer
(6pcs)

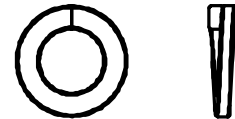

#79 - Ø10 x 2T
Spring Washer
(6pcs)

STEP3



#68 - M5x12mm
Phillips Head Screw
(8pcs)

STEP4



#68 - M5 x12mm
Phillips Head Screw
(4pcs)



#69 - M5 x 25m/m
Phillips Head Screw
(2pcs)



#83 - 3.5 x 12m/m
Sheet Metal Screw
(18pcs)

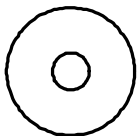

#75 - Ø5.5 x Ø19 x 1.5T
Flat Washer
(8pcs)

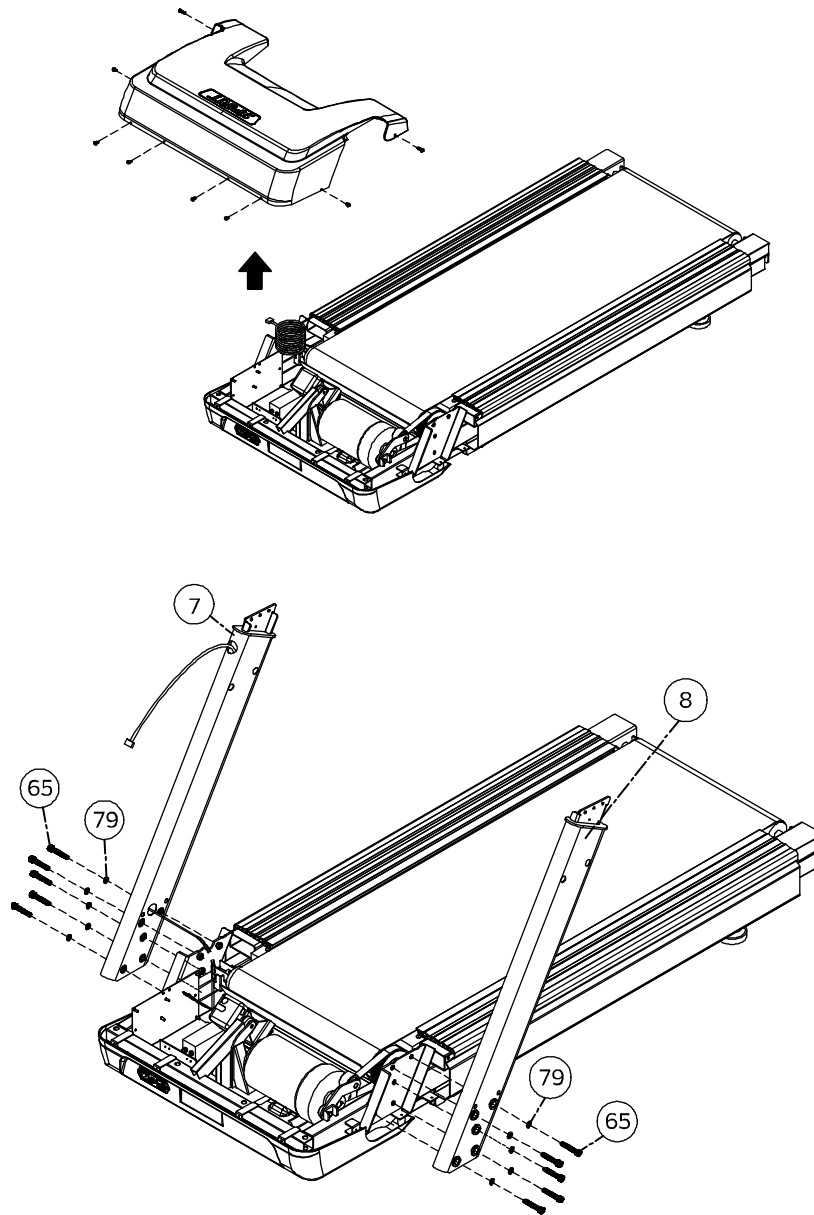

STEP 1

1. Loosen the 8 screws holding the MOTOR COVER (37) in place and remove the cover.
2. Uncoil wiring harness and run wires through the RIGHT UPRIGHT (7).
3. Use 5 BOLTS (65) and 5 SPRING WASHERS (79) to attach the RIGHT UPRIGHT (7) to the MAIN FRAME (1). Do not pinch wires. Do not tighten before putting the console on.
4. Use 5 BOLTS (65) and 5 SPRING WASHERS (79) to attach the LEFT UPRIGHT (8) to the MAIN FRAME (1). Do not tighten before putting the console on.

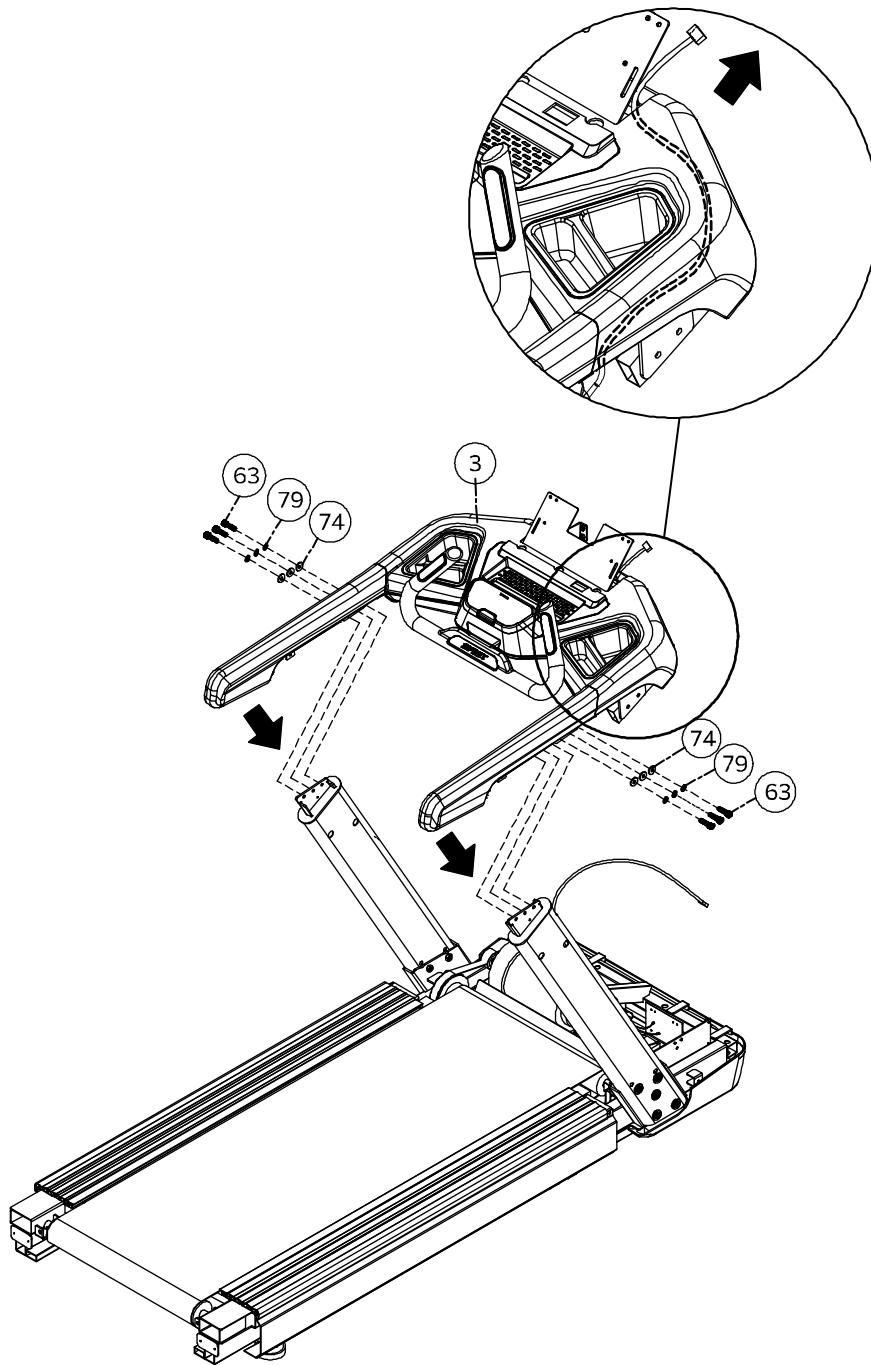

STEP 2

1. Install CONSOLE MOUNTING BRACKET (3) onto the uprights using 6 BOLTS (63), 6 SPRING WASHERS (79) and 6 FLAT WASHERS (74).
2. Run the wiring harness through the CONSOLE MOUNTING BRACKET (3) as shown in the illustration.
3. Tighten all bolts and washers on both uprights (7 and 8) from previous step.

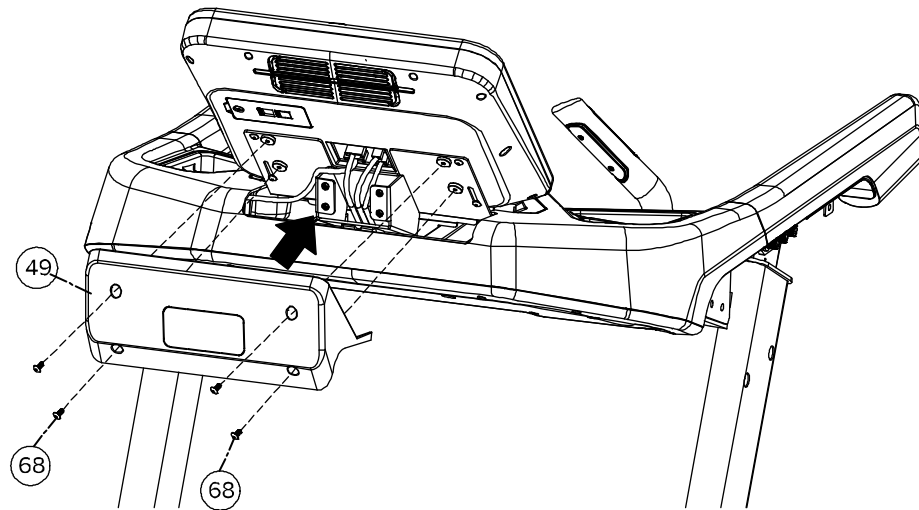
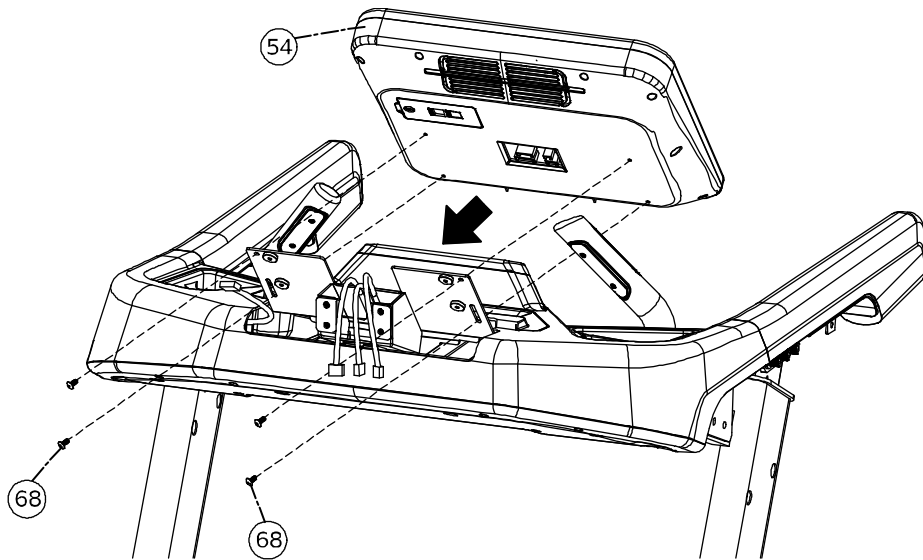

STEP 3

1. Wires should be away from the console mounting bracket.
2. Install the CONSOLE (54) using 4 SCREWS (68).
3. Connect wiring harness to CONSOLE (54).
4. Attach CONSOLE BRACKET COVER (49) to MAIN PANEL using 4 SCREWS (68).

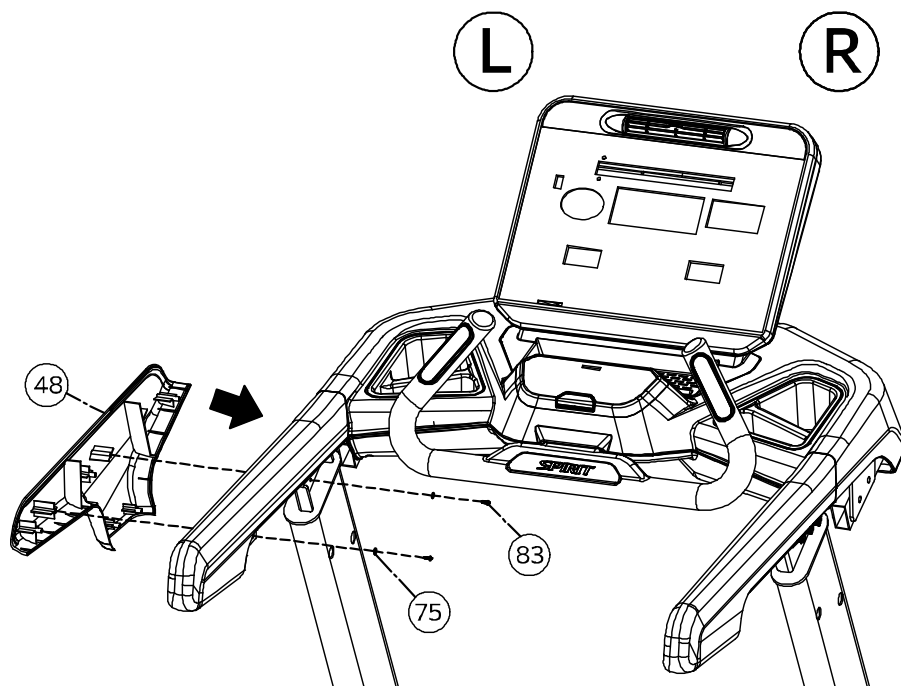

STEP 4

1. Attach LEFT OUTER HANDRAIL COVER (48) to MAIN PANEL using 2 SCREWS (83) and 2 FLAT WASHERS (75).

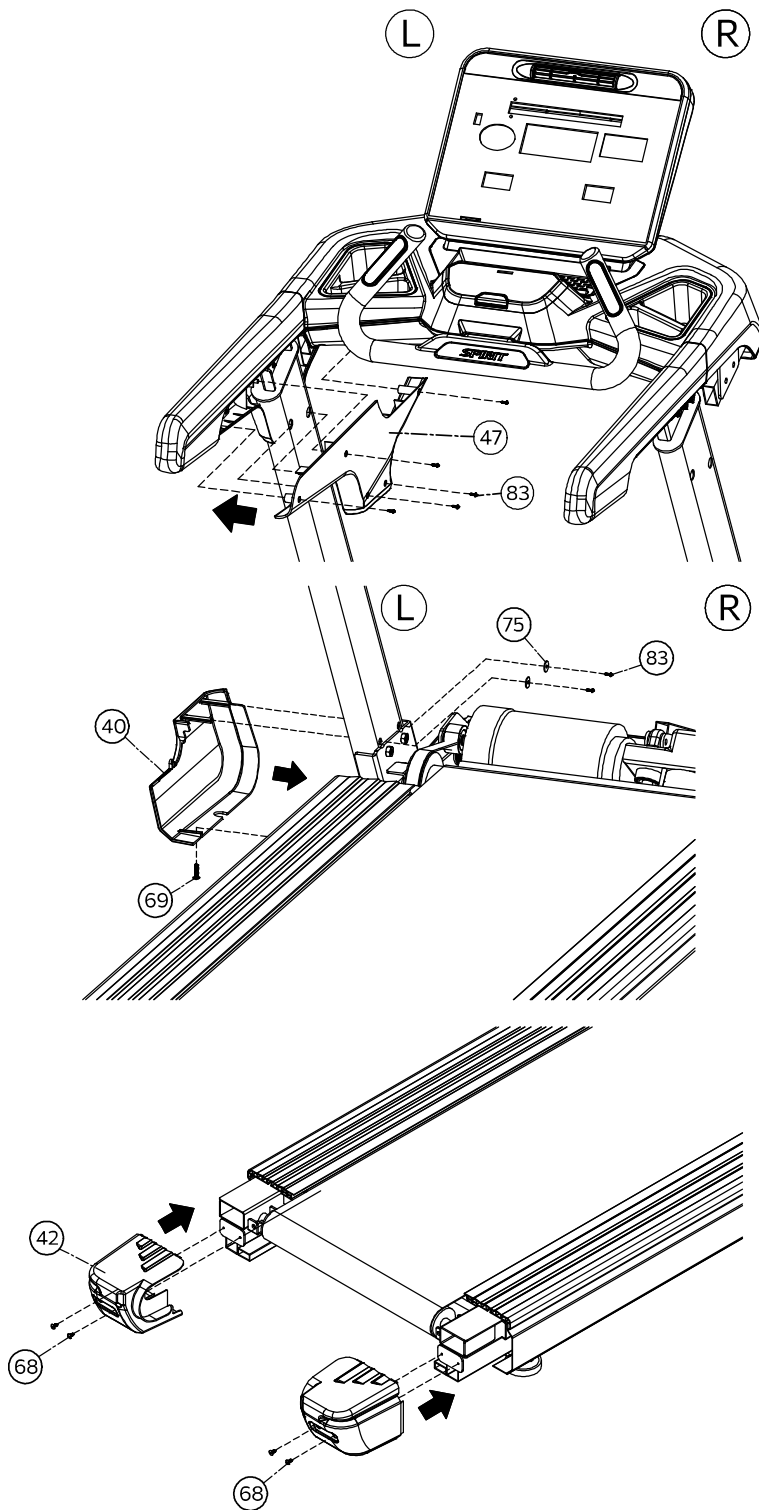

STEP 4

2. Attach LEFT INNER HANDRAIL COVER (47) to MAIN PANEL using 5 SCREWS (83).
3. Attach LEFT LOWER UPRIGHT COVER (40) to MAIN FRAME (1) using 2 SCREWS (83), 2 FLAT WASHERS (75), and 1 long SCREW (69).
4. Attach LEFT END CAP (42) to MAIN FRAME (1) using 2 SCREWS (68).
5. Repeat to install right side covers (45, 46, 39, 41).
6. Reinstall the MOTOR COVER (37) using the bolts removed in Step1.

OPERATION OF YOUR TREADMILL

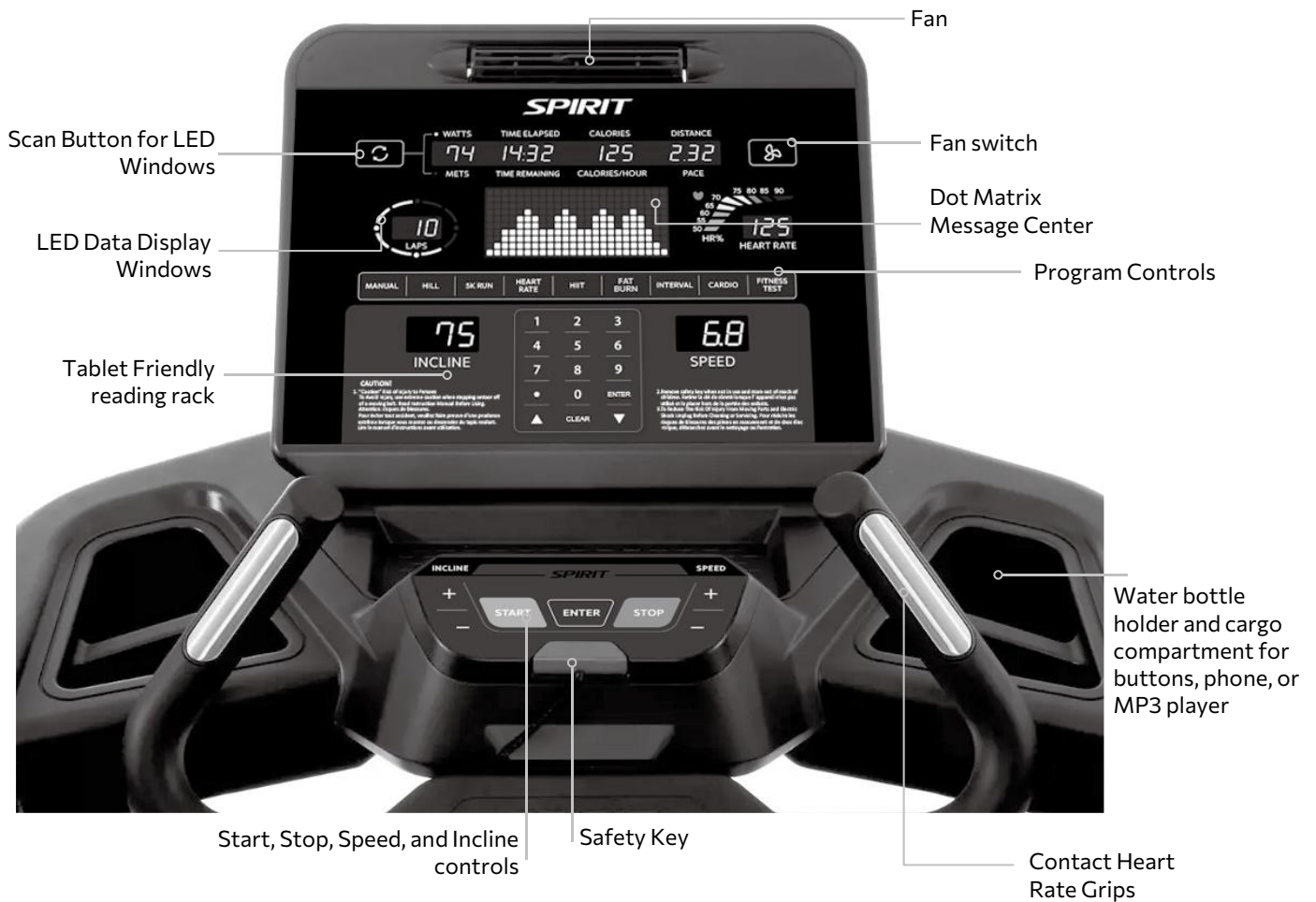

POWER

Power the treadmill on by plugging it into an appropriate wall outlet, then turn on the power switch located at the front of the treadmill below the motor hood. Ensure that the safety key is installed, as the treadmill will not power on without it.

When the power switch is turned on the treadmill console will take around 10 seconds to power on. The console will then enter idle mode, which is the starting point for operation.

C-SAFE FEATURE

Your console is equipped with a C-SAFE feature. The Power (POWER) port can be used for powering a remote-controlled audio-visual system by connecting a cable from the remote to the Power port at the back of the console.

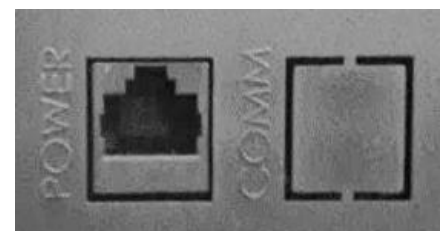

CONSOLE OPERATION

QUICK START

- Press any key to wake the display up if not already on.
- Press the Start key to begin belt movement at 0.5 mph / 0.8 kph then adjust to the desired speed using the Speed +/- keys, or by typing the desired speed on the numeric keypad. Once the setting desired is selected press Enter.
- To stop the tread-belt press and release the Stop key.

PAUSE/STOP/RESET

- When the treadmill is running the pause feature may be utilized by pressing the red Stop key once. This will slowly decelerate the treadbelt to a stop. The incline will go to zero percent. The Time, Distance and Calorie readings will hold while the unit is in the pause mode. After 5 minutes the display will reset and return to the start-up screen.
- To resume your exercise when in Pause mode, press the Start key. The speed and incline will return to their previous settings.
- Pressing the Stop key twice will end the program and a workout summary will be displayed. If the Stop button is pressed a third time, the console will return to idle mode (start-up screen).
- If the Stop button is held down for more than three seconds the console will reset.
- When you are setting data, such as age and time, for a program pressing the Stop key will allow you to go back one step for each key press.

INCLINE

- Incline may be adjusted any time after the belt starts moving.
- Press and hold the adjustment Incline +/- keys to achieve the desired level of incline.
- The display will indicate incline numbers as percent of grade (the same as the grade of a road) as adjustments are made.

DOT MATRIX CENTER DISPLAY

Ten rows of dots indicate each level of a workout in manual mode. The dots are only to show an approximate level (speed/incline) of effort. They do not necessarily indicate a specific value, only an approximate percent to compare levels of intensity. In Manual Operation the Speed / Incline dot matrix window will build a profile “picture” as values are changed during a workout. There are twenty-four columns, indicating time. The 24 columns are divided into 1/24th of the total time of the program. When the time is counting up from zero (as in quick start) each column represents 1 minute.

0.4 KM (1/4 MILE) TRACK

The 1/4-mile track (0.4 km) and lap counter are located to the left of the dot matrix window. The flashing dot indicates your progress. In the center of the track, there is a lap counter for reference.

HEART RATE FEATURE

The Pulse (Heart Rate) window will display your current heart rate in beats per minute during the workout. You must use both left and right stainless steel sensors to pick up your pulse. Pulse values are displayed any time the computer is receiving a Grip Pulse signal. You may use the Grip Pulse feature while in Heart Rate Control. The CT900 will also pick up wireless heart rate transmitters that are Polar compatible, including coded transmissions.

HEART RATE BAR GRAPH

Displays a graphical representation of your heart rate as a percentage of your estimated maximum heart rate. When you enter your age during programming, the console will calculate your maximum heart rate and then light up the graph to show the percent of the estimated maximum heart rate you are currently achieving.

MESSAGE WINDOW DISPLAY

Displays messages that help guide you through the programming process. During a program, the message window displays your workout data.

PROGRAMMABLE FEATURES

The Spirit Fitness CT900 offers a variety of exercise program options to choose from: Manual, Four Preset Programs (Hill, Fat Burn, Cardio, Interval), 5K Run, Heart Rate Control, High-Intensity Interval Training (HIIT), and Nine Fitness Testing Protocols: Gerkin, WFI, Army (pft), Navy (prt), Air Force (prt), Marines (pft), Law Enforcement (peb), U.S. Coast Guard and U.K. Chester Fireman (Performance & Prediction protocols).

To Select and Start a Preset Program

1. Select a preset program key then press Enter to begin customizing the program with your personal data, or just press the Start key to begin the program with the default settings.
2. After selecting a program and pressing enter to set your personal data, the Message window will prompt you through the settings starting with time. The default value of 20 minutes will be displayed and you may press Enter to accept or change it using the keypad or Up / Down keys and just press enter to move to the next step
3. The Message Window will now be blinking a value indicating your Age. Entering the correct age will affect the Heart Rate Bar Graph accuracy and is also needed for the HR programs. Use the keypad or Up / Down keys to adjust, and then press enter.
4. The Message Window will now be blinking a value indicating your body weight. Entering your correct body weight affects the Calorie readout accuracy. Use the keypad or Up / Down keys to adjust, and then press Enter.
5. The Message Window will now be blinking, showing the preset top speed of the selected program. Use the keypad or Up / Down keys to adjust and then press Enter. Each program has various speed changes throughout; this allows you to limit the highest speed the program will attain during your workout.
6. Now press the Start key to begin your workout, or the Stop button to return to the previous screen.
7. There will be a 3-minute warm-up to begin. You can press the Start button to bypass this and go straight to the workout. During the warm-up, the clock will count down from three minutes.

PRESET PROGRAMS SPEED/INCLINE SETTINGS

The preset program Speed and Incline levels are shown in the chart below. The Speed numbers shown in the chart indicate a percentage of the top speed of the program. For instance, the first Speed setting for P1 (Program 1, Hill) shows the number 20. This means that this segment of the program will have a speed that is 20% of the top speed for the program (The user sets the top speed in the procedure above). If the user sets the top speed to 10 mph / 16 kph, then the first segment will be 2 mph / 3.2 kph. You will notice that segment 12 shows 100 which means, the speed will be set to 100% of 10 mph/ 16 kph or simply 10 mph / 16 kph.

P1= HILL; P2= FAT BURN; P3= CARDIO; P4= INTERVAL

Prog	SEG	Warm up	1	2	3	4	5	6	7	8	9	10	11	12	13	14	15	16	17	18	19	20	21	22	23	24	Cool down				
P1	Speed	20	30	40	50	60	60	70	70	70	80	80	70	80	80	100	100	70	80	80	70	70	80	80	70	60	60	50	40	30	20
	Incline	0	0	0	0	1	2	3	3	4	3	3	4	4	5	3	3	4	3	3	4	4	5	4	3	1	1	0	0	0	0
P2	Speed	20	30	40	50	60	60	70	80	100	100	100	100	100	100	100	100	100	100	100	100	100	100	100	80	70	60	50	40	30	20
	Incline	0	0	0	0	1	2	3	3	3	4	5	3	3	4	4	3	3	2	2	3	4	5	6	4	2	1	0	0	0	0
P3	Speed	20	30	40	50	60	60	70	70	70	80	70	70	80	80	60	70	80	80	70	70	70	100	70	80	60	60	50	40	30	20
	Incline	0	0	0	0	1	1	1	2	2	3	2	2	3	3	1	2	3	3	2	2	4	4	2	3	1	1	0	0	0	0
P4	Speed	20	30	40	50	60	60	70	80	100	60	60	70	80	100	60	70	100	60	70	100	60	70	80	70	60	60	50	40	30	20
	Incline	0	0	0	0	1	2	3	5	6	2	3	5	6	7	2	3	7	2	3	8	2	3	5	4	3	1	0	0	0	0

HIIT PROGRAM

The HIIT, or High Intensity Interval Training, program takes advantage of the latest trend in fitness. During the program, you will perform short bursts of high-intensity sprinting followed by short rest periods. HIIT is a fully customizable interval training program. You can enter the number of intervals, the time of each interval Sprint and Rest period and the work intensity of the levels.

1. Press the HIIT key then Enter. The Message Window will ask you to enter your Age. You may enter your Age, using the Up and Down keys or the numeric keypad, then press the Enter key to accept the new number and proceed on to the next screen.
2. You are now asked to enter your Weight. You may adjust the Weight number using the Up and Down keys or the numeric keypad then press Enter to continue.
3. Next you are asked for the number of intervals you want to do. The default is 10 and the range available is 3 to 15. One interval equals 1 Sprint and 1 Rest segment.
4. Next is entering the Interval time. The Message Window shows: Sprint: 30 | Rest: 30. The Sprint time will be blinking. You may use the + - keys to adjust the Sprint time from 30 to 60 seconds then press Enter. The time for the Rest period will blink and you can adjust the time using the + - keys and press Enter. The Message Window will display the total program time.
5. The Message Window now displays SPRINT SPD 6.0 MPH / 9.6 kph. Use the Up and Down keys to adjust the sprint speed you desire and press enter.
6. The Message Window now displays REST SPEED 3.0 MPH / 4.8 kph. Use the Up and Down keys to adjust the rest speed you desire and press enter.
7. You may now press Start to begin the HIIT program. The program starts with a 3-minute warm-up period with the speed set to 50% of the sprint speed selected previously. You can manually adjust the speed during warm-up if you wish.

5K RUN

This program automatically sets a 5K distance as your goal. The track display will show one loop that is the equivalent of 5 kilometers and the Distance window will also show 5K to start. When the program begins the Distance will count down; once it reaches zero the program ends.

**Please note that the Speed readout is in MPH if the console is not set to Metric.*

FITNESS TEST

When the Fit Test key is pressed the DM displays: GERKIN. This is the first of 9 different tests available: Gerkin, WFI, Army (pft), Navy (prt), Air Force (prt), Marines (pft), Law Enforcement (peb), U.S. Coast Guard, and U.K. Chester Fireman (Performance & Prediction protocols). The initial test is GERKIN; to select a different test press the Fitness Test key again and the next test will be shown. Continue to press the Fitness Test key until the test you want is shown in the message window. To select your desired fitness test, press Enter.

FIT TEST OPERATION

1. For each program the Message Window will prompt you to enter your personal data such as Age, Weight, Height, Gender. You may adjust the settings using the keypad or Up and Down keys then press the Enter key to accept the new number and proceed on to the next screen.
2. After all required data is entered you may now press Start to begin the test.

ARMY

A timed 2 mile / 3.2 kph run. You control the speed manually.

Maximum time allowed to pass the test:

Age	Male	Female
17-21	16:36	19:42
22-26	17:30	20:36
27-31	17:54	21:42
32-36	18:48	23:06
37-41	19:30	24:06

For more detailed information, visit: <http://bit.ly/SF-Army>

AIR FORCE

A timed 1.5 mile / 2.4kph run. You control the speed manually.

Maximum time allowed to pass the test:

Age	Male	Female
<30	13:36	16:22
30-39	14:00	16:57
40-49	14:52	18:14
50-59	16:22	19:42
60+	18:14	22:28

For more detailed information, visit: <http://bit.ly/SF-AirForce>

NAVY

A timed 1.5 mile/ 2.4 kph run. You control the speed manually.

Maximum time allowed to pass the test:

Age	Male	Female	Age	Male	Female
17-21	16:36	19:42	45-49	16:09	17:02
22-26	17:30	20:36	50-54	16:46	17:27
27-31	17:54	21:42	55-59	17:10	18:35
32-36	18:48	23:06	60-64	18:53	19:44
37-41	19:30	24:06	65+	20:36	20:53

For more detailed information, visit: <http://bit.ly/SF-Navy>

MARINES

A timed 3 mile/ 4.8 kph run. You control the speed manually.

Maximum time allowed to pass the test:

Age	Male	Female
17-26	28:00	31:00
27-39	29:00	32:00
40-45	30:00	33:00
46+	33:00	36:00

For more detailed information, visit: <http://bit.ly/SF-Marines>

COAST GUARD

A timed 1.5 mile/ 2.4kph run. You control the speed manually. Maximum time allowed to pass the test:

Male	20-29 Yrs. Old	30-39 Yrs. Old	40-49 Yrs. Old	50-59 Yrs. Old	60+ Yrs. Old
Superior	<9:17	<9:33	<9:51	<10:37	<11:26
Excellent	9:18-10:09	9:34-10:46	9:52-11:15	10:28-12:08	11:27-13:23
Good	10:10-11:29	10:47-11:54	11:16-12:24	12:09-13:35	13:24-15:04
Fair	11:30-12:38	11:55-12:58	12:25-13:50	13:36-15:06	15:05-16:46
Poor	12:39-14:00	12:59-14:34	13:51-15:24	15:07-16:58	16:47-19:10
Very Poor	>14:00	>14:34	>15:24	>16:58	>19:10
Failure	>12:51	>13:36	>14:29	>15:26	>16:40
Female	20-29 Yrs. Old	30-39 Yrs. Old	40-49 Yrs. Old	50-59 Yrs. Old	60+ Yrs. Old
Superior	<10:28	<11:00	<11:33	<12:53	<14:05
Excellent	10:29-11:58	11:01-12:24	11:34-13:23	12:54-14:34	14:06-16:33
Good	11:59-13:24	12:25-14:08	13:24-14:53	14:35-16:35	16:34-18:27
Fair	13:25-14:50	14:09-15:43	14:54-16:31	16:36-18:18	18:28-20:16
Poor	14:51-16:46	15:44-17:38	16:32-18:37	18:19-20:44	20:17-22:52
Very Poor	>16:46	>17:38	>18:37	>20:44	>22:52
Failure	>15:26	>15:57	>16:58	>17:55	>18:44

LAW ENFORCEMENT (PEB)

A timed 1.5 mile / 2.4kph run. You control the speed manually. Maximum time allowed to pass the test:

For more detailed information, visit: <https://www.fletc.gov/peb-scores-age-and-gender>

GERKIN

The Gerkin protocol, also known as the fireman's protocol, is a sub-max Vo2 (volume of oxygen) test.

The test will increase speed and elevation alternately until you reach 85% of your Max heart rate. The time it takes for you to reach 85% determines the test score (VO2max) as shown in the chart below.

Stage	Time	Speed	Grade	VO2 Max
1	0 to 1:00	7.2KPH	0%	31.15
2.1	1:00	7.2KPH	2%	32.55
2.2	1:30	7.2KPH	2%	33.6
2.3	1:45	7.2KPH	2%	34.65
2.4	2:00	8.0KPH	2%	35.35
3.1	2:15	8.0KPH	2%	37.45
3.2	2:30	8.0KPH	2%	39.55
3.3	2:45	8.0KPH	2%	41.3
3.4	3:00	8.0KPH	4%	43.4
4.1	3:15	8.0KPH	4%	44.1
4.2	3:30	8.0KPH	4%	45.15
4.3	3:45	8.0KPH	4%	46.2
4.4	4:00	8.8KPH	4%	46.5
5.1	4:15	8.8KPH	4%	48.6
5.2	4:30	8.8KPH	4%	50
5.3	4:45	8.8KPH	4%	51.4
5.4	5:00	8.8KPH	6%	52.8
6.1	5:15	8.8KPH	6%	53.9
6.2	5:30	8.8KPH	6%	54.9
6.3	5:45	8.8KPH	6%	56
6.4	6:00	9.6KPH	6%	57
7.1	6:15	9.6KPH	6%	57.7
7.2	6:30	9.6KPH	6%	58.8
7.3	6:45	9.6KPH	6%	60.2
7.4	7:00	9.6KPH	8%	61.2
8.1	7:15	9.6KPH	8%	62.3
8.2	7:30	9.6KPH	8%	63.3
8.3	7:45	9.6KPH	8%	64
8.4	8:00	10.4KPH	8%	65
9.1	8:15	10.4KPH	8%	66.5
9.2	8:30	10.4KPH	8%	68.2
9.3	8:45	10.4KPH	8%	69
9.4	9:00	10.4KPH	10%	70.7
10.1	9:15	10.4KPH	10%	72.1
10.2	9:30	10.4KPH	10%	73.1
10.3	9:45	10.4KPH	10%	73.8
10.4	10:00	11.2KPH	10%	74.9
11.1	10:15	11.2KPH	10%	76.3
11.2	10:30	11.2KPH	10%	77.7
11.3	10:45	11.2KPH	10%	79.1
11.4	11:00	11.2KPH	10%	80

Stage	Time	Speed	Grade	VO2 Max
1	0 to 1:00	4.5MPH	0%	31.15
2.1	1:00	4.5MPH	2%	32.55
2.2	1:30	4.5MPH	2%	33.6
2.3	1:45	4.5MPH	2%	34.65
2.4	2:00	5.0MPH	2%	35.35
3.1	2:15	5.0MPH	2%	37.45
3.2	2:30	5.0MPH	2%	39.55
3.3	2:45	5.0MPH	2%	41.3
3.4	3:00	5.0MPH	4%	43.4
4.1	3:15	5.0MPH	4%	44.1
4.2	3:30	5.0MPH	4%	45.15
4.3	3:45	5.0MPH	4%	46.2
4.4	4:00	5.5MPH	4%	46.5
5.1	4:15	5.5MPH	4%	48.6
5.2	4:30	5.5MPH	4%	50
5.3	4:45	5.5MPH	4%	51.4
5.4	5:00	5.5MPH	6%	52.8
6.1	5:15	5.5MPH	6%	53.9
6.2	5:30	5.5MPH	6%	54.9
6.3	5:45	5.5MPH	6%	56
6.4	6:00	6.0MPH	6%	57
7.1	6:15	6.0MPH	6%	57.7
7.2	6:30	6.0MPH	6%	58.8
7.3	6:45	6.0MPH	6%	60.2
7.4	7:00	6.0MPH	8%	61.2
8.1	7:15	6.0MPH	8%	62.3
8.2	7:30	6.0MPH	8%	63.3
8.3	7:45	6.0MPH	8%	64
8.4	8:00	6.5MPH	8%	65
9.1	8:15	6.5MPH	8%	66.5
9.2	8:30	6.5MPH	8%	68.2
9.3	8:45	6.5MPH	8%	69
9.4	9:00	6.5MPH	10%	70.7
10.1	9:15	6.5MPH	10%	72.1
10.2	9:30	6.5MPH	10%	73.1
10.3	9:45	6.5MPH	10%	73.8
10.4	10:00	7.0MPH	10%	74.9
11.1	10:15	7.0MPH	10%	76.3
11.2	10:30	7.0MPH	10%	77.7
11.3	10:45	7.0MPH	10%	79.1
11.4	11:00	7.0MPH	10%	80

WFI

The WFI test is a modified Gerkin protocol. The actual test is the same as the Gerkin chart above, but the score is calculated differently.

Before the Gerkin/ WFI Test:

1. Make sure you are in good health; check with your physician before performing any exercise if you are over the age of 35 or persons with pre-existing health conditions.
2. Make sure you have warmed up and stretched before taking the test.
3. Do not take in caffeine before the test.
4. Hold the hand grips gently, do not tense up.

During the Test:

1. The console must be receiving a steady heart rate for the test to begin. You may use the hand pulse sensors or wear a heart rate chest strap transmitter.
2. The test will start with a 3-minute warm-up at 3 MPH / 4.8 kph before the actual test begins.
3. The data shown during the test is:
 - a. Time indicates total elapsed time
 - b. Incline in percent grade
 - c. Distance in Miles or Kilometers depending on preset parameter.
 - d. Speed in MPH or KPH depending on preset parameter.
 - e. Target Heart Rate and Actual Heart Rate are shown in the Message Window.

After the Test

1. Cool down for about one to three minutes.
2. Take note of your score because the console will automatically return to the start-up mode after a few minutes.

WHAT YOUR SCORE MEANS

VO2max Chart for males and very fit females

	18-25 years old	26-35 years old	36-45 years old	46-55 years old	56-65 years old	65+ years old
excellent	>60	>56	>51	>45	>41	>37
good	52-60	49-56	43-51	39-45	36-41	33-37
above average	47-51	43-48	39-42	35-38	32-35	29-32
average	42-46	40-42	35-38	32-35	30-31	26-28
below average	37-41	35-39	31-34	29-31	26-29	22-25
poor	30-36	30-34	26-30	25-28	22-25	20-21
very poor	<30	<30	<26	<25	<22	<20

VO2max Chart for females and de-conditioned males

	18-25 years old	26-35 years old	36-45 years old	46-55 years old	56-65 years old	65+ years old
excellent	56	52	45	40	37	32
good	47-56	45-52	38-45	34-40	32-37	28-32
above average	42-46	39-44	34-37	31-33	28-31	25-27
average	38-41	35-38	31-33	28-30	25-27	22-24
below average	33-37	31-34	27-30	25-27	22-24	19-22
poor	28-32	26-30	22-26	20-24	18-21	17-18
very poor	<28	<26	<22	<20	<18	<17

CHESTER TREADMILL TEST

This test has two modes: CTT Performance and CTT Prediction (of Aerobic Capacity).

CTT PERFORMANCE

CTT Performance is a 12-minute graded, treadmill walk test with a fixed speed of 6.2km/hr designed to assess whether or not the subject can achieve the minimum recommended standard for aerobic capacity, namely 42mlsO₂/kg/min.

Procedures:

1. Check there are no medical contraindications to performing exhaustive exercise
2. Subject walks at 6.2km/hr at 0% for 2 mins
3. Every 2 mins increase gradient by 3%
4. Test is completed after 12 mins
5. Test should be stopped if subject is showing overt signs of distress and exhaustion or RPE=18+

CTT Prediction

CTT Prediction is a submaximal test designed to predict aerobic capacity

1. Same walk protocol as CTT Performance but wearing HR monitor
2. Test is stopped when the subject reaches 80%HRMax or RPE=14
3. A VO₂ score is given at the end of the test

HEART RATE PROGRAM

Heart Rate Control (HRC) uses your treadmill's incline system to control your heart rate via information from pulse grips or wireless chest strap. Increases and decreases in elevation affect heart rate much more efficiently than changes in speed alone. The HRC program automatically changes elevation gradually to achieve the programmed target heart rate.

Selecting a Heart Rate Control Program:

You have the option, during the setup mode, to choose either the Weight Control (HR 1) program or the Cardiovascular (HR 2) program. The Weight Control program will attempt to maintain your heart rate at 60% of your Maximum Heart Rate. The Cardiovascular program will attempt to maintain your heart rate at 85% of your Maximum Heart Rate. Your Maximum Heart Rate is based upon a formula that subtracts your age from a constant of 220. Your HR setting is automatically calculated during the setup mode when you enter your age.

Heart Rate Control Programming:

1. Press HR button to enter heart rate program.
2. Now the window will show PRESS ENTER TO MODIFY OR START TO BEGIN WORKOUT. You can either press the Enter button for settings or press the Start button to execute the program.
3. When the Enter button is pressed, the Message Window shows PRESS 1 OR 2 TO SELECT THEN PRESS ENTER.

At the same time, the dot matrix window is showing "1" and you can press numeric keypad 1 or 2 and then the Enter button.
4. Now Message Window is showing ADJUST TIME THEN PRESS ENTER with Time Window blinking. Use Up/Down keys or numeric keys to adjust. After setting time, press the Enter button again.
5. Now Message Window is showing ADJUST AGE THEN PRESS ENTER with Incline Window blinking. Use Up/Down/ Fast/Slow keys or numeric keys to adjust. Adjusting age will change THR value (as the THR formula described previously). After age is set, press the Enter button again.
6. Now Message Window is showing ADJUST BODY WEIGHT THEN PRESS ENTER with Incline Window blinking. Use Up/Down keys or numeric keys to adjust. After the weight is set, press Enter button again.
7. Now Message Window is showing ADJUST HEART RATE THEN PRESS ENTER with Speed Window blinking. Use Up/Down keys or numeric keys to adjust. After the target heart rate value is set, press the Enter button again.
8. The Message Window is then showing PRESS START TO BEGIN WORKOUT OR ENTER TO MODIFY. Press Start button to begin the workout or Stop button to return to the previous screen.

Note: When the Message Window is showing CHECK PULSE, there is no pulse signal received and the program cannot be performed. Please check and make sure that heart rate strap functions normally.

USING A HEART RATE TRANSMITTER (OPTIONAL)

How to wear your wireless chest strap transmitter:

1. Attach the transmitter to the elastic strap using the locking parts.
2. Adjust the strap as tightly as possible as long as the strap is not too tight to remain comfortable.
3. Position the transmitter with the logo centered in the middle of your body facing away from your chest (some people must position the transmitter slightly left of center). Attach the final end of the elastic strap by inserting the round end and, using the locking parts, secure the transmitter and strap around your chest.
4. Position the transmitter immediately below the pectoral muscles.
5. Sweat is the best conductor to measure very minute heart beat electrical signals. However, plain water can also be used to pre-wet the electrodes (2 ribbed oval areas on the reverse side of the belt and both sides of the transmitter). It's also recommended that you wear the transmitter strap a few minutes before your work out. Some users, because of body chemistry, have a more difficult time in achieving a strong, steady signal at the beginning. After "warming up", this problem lessens. As noted, wearing clothing over the transmitter/strap doesn't affect performance.
6. Your workout must be within range - distance between transmitter/receiver – to achieve a strong steady signal. The length of range may vary somewhat but generally stay close enough to the console to maintain good, strong, reliable readings. Wearing the transmitter immediately against bare skin assures you of proper operation. If you wish, you may wear the transmitter over a shirt. To do so, moisten the areas of the shirt that the electrodes will rest upon.



Note: The transmitter is automatically activated when it detects activity from the user's heart. Additionally, it automatically deactivates when it does not receive any activity. Although the transmitter is water resistant, moisture can have the effect of creating false signals, so you should take precautions to completely dry the transmitter after use to prolong battery life (estimated transmitter battery life is 2500 hours). The replacement battery is Panasonic CR2032.

WARNING!

DO NOT USE THE HEART RATE CONTROL PROGRAM IF YOUR HEART RATE IS NOT REGISTERING PROPERLY ON THE TREADMILL'S DISPLAY!

HEART RATE PROGRAMS

The old motto, “no pain, no gain”, is a myth that has been overpowered by the benefits of exercising comfortably. A great deal of this success has been promoted by the use of heart rate monitors. With the proper use of a heart rate monitor, many people find that their choice of exercise intensity is either too high or too low and exercise is much more enjoyable by maintaining their heart rate in the desired benefit range.

To determine the benefit range in which you wish to train, you must first determine your Maximum Heart Rate. This can be accomplished by using the following formula: 220 minus your age. This will give you the Maximum heart rate (MHR) for someone of your age. To determine the effective heart rate range for specific goals you simply calculate a percentage your MHR. Your Heart rate training zone is 50% to 90% of your maximum heart rate. 60% of your MHR is the zone that burns fat while 80% is for strengthening the cardio vascular system. This 60% to 80% is the zone to stay in for maximum benefit.

For someone who is 40 years old their target heart rate zone is calculated:

$220 - 40 = 180$ (maximum heart rate)
 $180 \times .6 = 108$ beats per minute (60% of maximum)
 $180 \times .8 = 144$ beats per minute (80% of maximum)

So for a 40 year old the training zone would be 108 to 144 beats per minute.

If you enter your age during programming the console will perform this calculation automatically. Entering your age is used for the Heart Rate control programs. After calculating your Maximum Heart Rate you can decide upon which goal you would like to pursue.

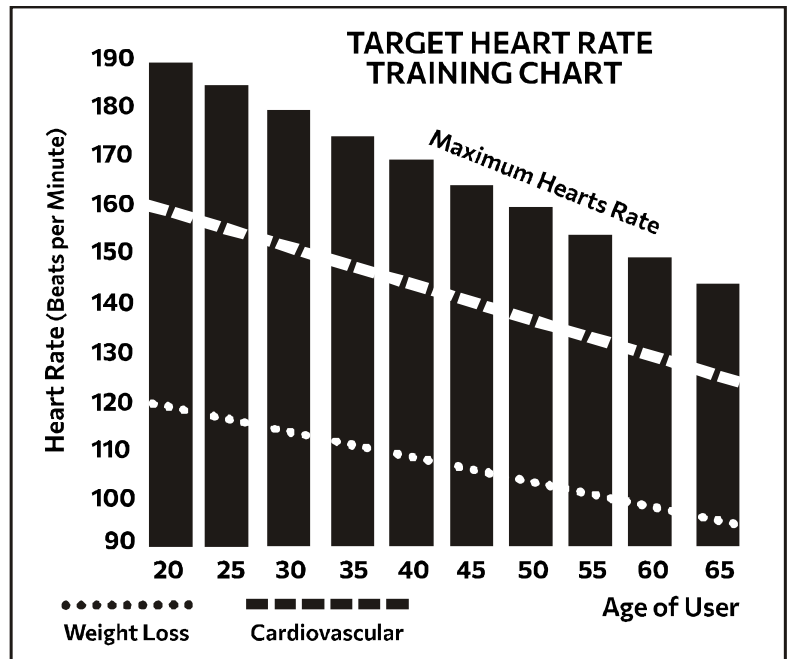

The two most popular reasons for, or goals, of exercise are cardiovascular fitness (training for the heart and lungs) and weight control. The black columns on the chart above represent the Maximum Heart Rate for a person whose age is listed at the bottom of each column. The training heart rate, for either cardiovascular fitness or weight loss, is represented by two different lines that cut diagonally through the chart. A definition of the lines’ goal is in the bottom left-hand corner of the chart. If your goal is cardiovascular fitness or if it is weight loss, it can be achieved by training at 80% or 60%, respectively, of your Maximum Heart Rate on a schedule approved by your physician. Consult your physician before participating in any exercise program.

CAUTION!

The target value used in HR programs is a suggestion only for normal, healthy individuals. Do not exceed your limits! You may not be able to obtain your chosen target. If in question, enter a higher age value that will set a lower target goal.

RATE OF PERCEIVED EXERTION

Heart rate is important but listening to your body also has a lot of advantages. There are more variables involved in how hard you should workout than just heart rate. Your stress level, physical health, emotional health, temperature, humidity, the time of day, the last time you ate and what you ate, all contribute to the intensity at which you should workout. If you listen to your body, it will tell you all of these things.

The rate of perceived exertion (RPE), also known as the Borg scale, was developed by Swedish physiologist G.A.V. Borg. This scale rates exercise intensity from 6 to 20 depending upon how you feel or the perception of your effort.

The scale is as follows:

Rating Perception of Effort

- 6 Minimal
- 7 Very, very light
- 8 Very, very light +
- 9 Very light
- 10 Very light +
- 11 Fairly light
- 12 Comfortable
- 13 Somewhat hard
- 14 Somewhat hard +
- 15 Hard
- 16 Hard +
- 17 Very hard
- 18 Very hard +
- 19 Very, very hard
- 20 Maximal

You can get an approximate heart rate level for each rating by simply adding a zero to each rating. For example a rating of 12 will result in an approximate heart rate of 120 beats per minute. Your RPE will vary depending upon the factors discussed earlier. That is the major benefit of this type of training. If your body is strong and rested, you will feel strong and your pace will feel easier. When your body is in this condition, you are able to train harder and the RPE will support this. If you are feeling tired and sluggish, it is because your body needs a break. In this condition, your pace will feel harder. Again, this will show up in your RPE and you will train at the proper level for that day.

EXPLODED VIEW DIAGRAM

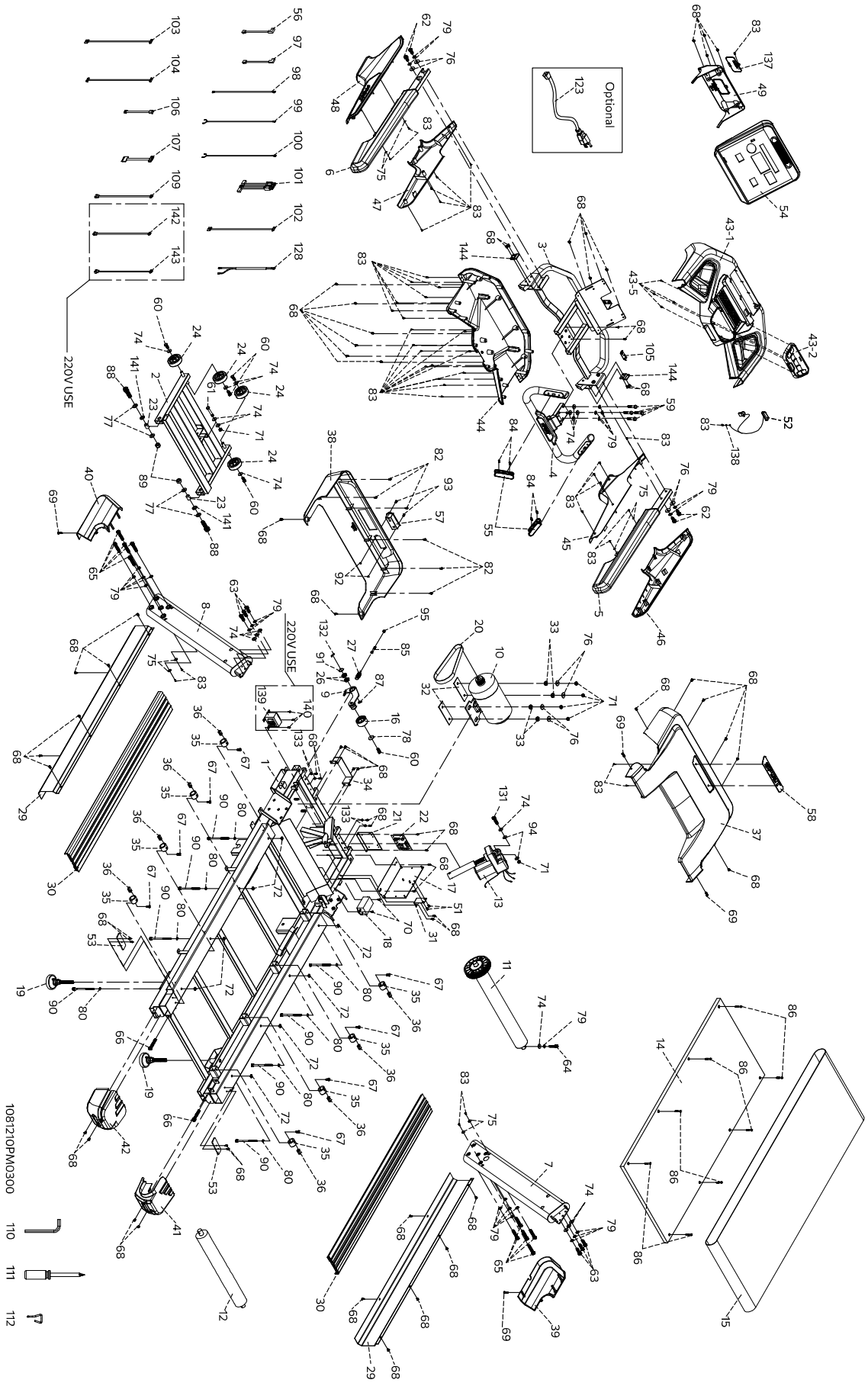

PARTS LIST

KEY NO.	DESCRIPTION	Q'TY
1	Main Frame	1
2	Incline Bracket	1
3	Console Mounting Bracket	1
4	Hand pulse Assembly	1
5	Handrail (R)	1
6	Handrail (L)	1
7	Right Upright	1
8	Left Upright	1
9	Idler Wheel Assembly	1
10	AC Motor	1
11	Front Roller W/Pulley	1
12	Rear Roller	1
13	Incline Motor	1
14	Running Deck	1
15	Running Belt	1
16	Axle for Idler Wheel	1
17	Motor Inverter	1
18	AC Power Filter	1
19	Leveling Foot Pad	2
20	Drive Belt	1
21	Interface Board Bracket	1
22	Inverter Board	1
23	Copper Bushing	2
24	Transportation Wheel	4
26	6902_Bearing	2
27	Idler Spring	1
29	Aluminum Side Rail (R)	2
30	Step Rail	2
31	Inverter Support Bracket	1
32	Motor Insulator	2
33	Motor Insulating bushing	4
34	Interface Dummy Bracket	1
35	Deck Cushion	8
36	Speed Nut Clip	8
37	Motor Top Cover	1
38	Motor Bottom Cover	1
39	Lower Upright Cover (R)	1
40	Lower Upright Cover (L)	1
41	End Cap (R)	1
42	End Cap (L)	1
43	Beverage Holder Cover	1
43~01	Beverage Holder Cover	1
43~02	Handlebar Cover Inner(R)	1
43~05	3.5 × 12m/m_Sheet Metal Screw	4
44	Beverage Holder Cover(Bottom)	1

KEY NO.	DESCRIPTION	Q'TY
45	Handrail Cover Inner (R)	1
46	Handrail Cover Outer (R)	1
47	Handrail Cover Inner (L)	1
48	Handrail Cover Outer (L)	1
49	Console Bracket Cover	1
51	M3 × 5m/m_Phillips Head Screw	2
52	Safety Key	1
53	Step Rail Rear Support Plate	2
54	Console Assembly	1
55	30m/m_Handpulse Assembly	2
56	450m/m_Connecting Wire(Black)	1
57	On/Off Switch	1
58	Top Motor Cover Plate	1
59	M10 × 50m/m_Hex Head Bolt	4
60	3/8" × 1" _Hex Head Bolt	5
61	M10 × 65m/m_Hex Head Bolt	1
62	M10 × P1.5 × 25m/m_Socket Head Cap Bolt	4
63	M10 × P1.5 × 35m/m_Socket Head Cap Bolt	6
64	M10 × P1.5 × 45m/m_Socket Head Cap Bolt	1
65	M10 × P1.5 × 60m/m_Socket Head Cap Bolt	10
66	M10 × P1.5 × 75m/m_Socket Head Cap Bolt	2
67	M8 × P1.25 × 20m/m_Flat Head Countersink Bolt	8
68	M5 × P0.8 × 12m/m_Phillips Head Screw	62
69	M5 × P0.8 × 25m/m_Phillips Head Screw	4
70	M4 × P0.7 × 12m/m_Phillips Head Screw	2
71	M10 × P1.25 × 8T_Nyloc Nut	6
72	M8 × P1.25 × 6.5T_Nyloc Nut	8
74	Ø3/8" × Ø25 × 3T_Flat Washer	18
75	Ø5.5 × Ø19 × 1.5T_Flat Washer	8
76	Ø3/8" × Ø30 × 3T_Flat Washer	8
77	Ø16.5 × Ø30 × 3T_Flat Washer	4
78	Ø10 × Ø35 × 2T_Flat Washer	1
79	Ø10 × 2T_Spring Washer	25
80	Ø8 × 1.5T_Spring Washer	8
82	Ø5 × 15m/m_Sheet Metal Screw	6
83	Ø3.5 × 12m/m_Sheet Metal Screw	40
84	Ø3 × 20m/m_Tapping Screw	4
85	M8 × 67L_Idle Wheel Screw	1
86	M6 × P1.0 × 40L_Flat Head Countersink Bolt	8
87	Ø15_C Ring	1
88	M16 × P2.0 × 55m/m_Socket Head Cap Bolt	2
89	M16 × 16T_Nyloc Nut	2
90	M8 × P1.25 × 140m/m_Socket Head Cap Bolt	8
91	Ø28_Wire Clamp	1
92	M5 × 5T_Nyloc Nut	2

KEY NO.	DESCRIPTION	Q'TY
93	M5 × 12m/m_Phillips Head Screw	2
94	Ø10 × Ø25 × 2.5T_Nylon Washer	2
95	M8 × 7T_Nyloc Nut	1
97	450m/m_Connecting Wire(White)	1
98	300m/m_Ground Wire	1
99	800m/m_Handpulse Wire(SMP3)	1
100	800m/m_Handpulse Wire(SMR4)	1
101	500m/m_Connecting Wire	1
102	350m/m_Conneting Wire(XHP-7)	1
103	350m/m_Conneting Wire(XHP-8)	1
104	2300m/m_Computer Cable	1
105	monitor module	1
106	800m/m_Connecting Wire	1
107	800m/m_Keyboard Wire	1
109	300m/m_Connecting Wire	1
110	M8 L Allen Wrench	1
111	Phillips Head Screw Driver	1
112	Short Phillips Head Screw Driver	1
123	Power Cord (Optional)	1
128	600m/m_Handpulse Wire	1
131	M10 × P1.5 × 50m/m_Hex Head Bolt(15L)	1
132	Ø15 × 0.3m/m_Wave Washer	1
133	M5_Star Washer	4
137	TV Holder Cover	1
138	Ø4 × Ø10 × 1T_Flat Washer	1
139	Choke(220V USE)	1
140	M5 × 6m/m_Phillips Head Screw(220V USE)	3
141	Ø17 × Ø28 × 2T_Nylon Washer	2
142	350m/m_Connecting Wire(220V USE)	1
143	60m/m_Connecting Wire(220V USE)	1
144	Beverage Holder Pad(Upper)	2

GENERAL MAINTENANCE

Belt and Deck - Your treadmill uses a very highly efficient low-friction deck. Performance is maximized when the deck is kept as clean as possible. Use a soft, damp cloth or paper towel to wipe the edge of the belt and the area between the belt edge and frame. Also, reach as far as practical directly under the belt edge. This should be done once a month to extend belt and deck life. Use water only - no cleaners or abrasives. A mild soap and water solution along with a nylon scrub brush will clean the top of the textured belt. **Allow the belt to dry before using.**

Belt Dust - This occurs during normal break-in or until the belt stabilizes. Wiping excess off with a damp cloth will minimize buildup.

General Cleaning - Dirt, dust, and pet hair can block air inlets and accumulate on the running belt. On a monthly basis: vacuum underneath your treadmill to prevent buildup. Once a year, you should remove the black motor hood and vacuum out dirt that may accumulate. **UNPLUG THE POWER CORD BEFORE THIS TASK.**

The low-maintenance (routine monthly cleaning), dual-sided hard wax deck is designed to withstand up to 32,000 kilometers on each side. If the original side of the deck shows significant wear, it needs to be flipped. Contact your service technician for assistance. Do not apply any type of lubricant or wax to the surface.

BELT ADJUSTMENTS:

Tread-belt Tension Adjustment - Adjustment must be made from the rear roller. The adjustment bolts are located at the end of the step rails in the end caps, as noted in the diagram below.

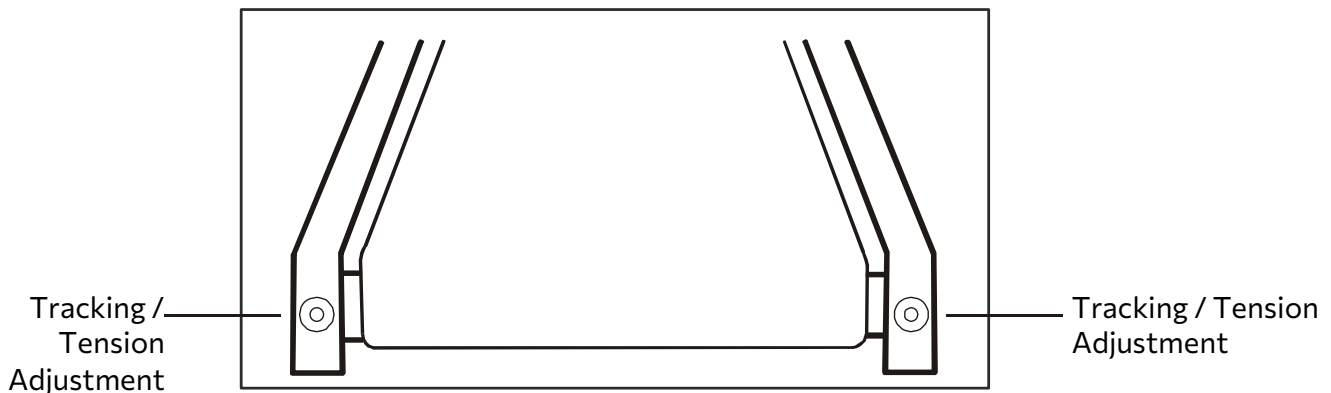

Note: Adjustment is through small hole in the end cap.

Tighten the rear roller bolts only enough to prevent slippage at the front roller. Turn both tread-belt tension adjustment bolts in increments of 1/4 turn each and inspect for proper tension by walking on the belt at a low speed, making sure the belt does not slip. When an adjustment is made to the belt tension, you must be sure to turn the bolts on both sides evenly or the belt could start tracking to one side instead of running in the middle of the deck.

DO NOT OVERTIGHTEN - Over-tightening will cause belt damage and premature bearing failure. If you feel the belt is tight enough, but it still slips, the problem may be a loose Motor drive belt under the front cover.

TREADBELT TRACKING ADJUSTMENT:

The performance of your treadmill is dependent on the frame running on a reasonably level surface. If the frame is not level, the front and back roller cannot run parallel, and constant belt adjustment may be necessary.

The treadmill is designed to keep the tread-belt reasonably centered while in use. It is normal for some belts to drift near one side while the belt is running with no one on it. After a few minutes of use, the tread-belt should have a tendency to center itself. If, during use, the belt continues to move toward one side, adjustments are necessary.

TO SET TREADBELT TRACKING:

An 8mm Allen wrench is provided for this adjustment. Make tracking adjustments on the left side bolt. Set the belt speed to 3 mph. Be aware that a small adjustment can make a dramatic difference which may not be apparent right away. If the belt is too close to the left side, then turn the bolt only a 1/4 turn to the right (clockwise) and wait a few minutes for the belt to adjust itself. Continue to make 1/4 turns until the belt stabilizes in the center of the running deck.

If the belt is too close to the right side, turn the bolt counterclockwise. The belt may require periodic tracking adjustment depending on use and walking/ running characteristics. Some users may affect tracking differently. Expect to make adjustments as required to center the treadbelt. Adjustments will become less of a maintenance concern as the belt is used. Proper belt tracking is an owner responsibility common with all treadmills.

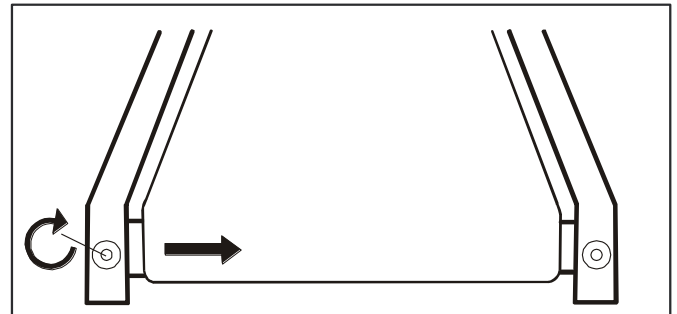

ATTENTION:

DAMAGE TO THE RUNNING BELT RESULTING FROM IMPROPER TRACKING / TENSION ADJUSTMENTS IS NOT COVERED UNDER THE SPIRIT WARRANTY.

Unplug treadmill before performing any maintenance.

Task	How To	Daily	Weekly	Monthly	Semi-Annually	Annually
Wipe down unit	Damp cloth w/ water	•				
Clean under belt	Towel or vacuum			•		
Check belt tension/tracking	Feel/visual		•			
Clean under motor cover	Vacuum carefully				•	
Check hardware	Wrench			•		
Inspect for deck wear	Visual				•	
Inspect drive belt	Visual				•	

SERVICE CHECKLIST - DIAGNOSIS GUIDE

Before contacting your dealer for aid, please review the following information. It may save you both time and expense. This list includes common problems that may not be covered under the treadmill's warranty.

PROBLEM	SOLUTION/CAUSE
Display does not light	1) Tether cord not in position. 2) Circuit breaker on front grill tripped. Push circuit breaker in until it locks. 3) Plug is disconnected. Make sure plug is firmly pushed into 120 VAC wall outlet. 4) Breaker panel circuit breaker may be tripped. 5) Treadmill defect. Contact your dealer.
Treadbelt does not stay centered Treadmill belt hesitates when walked/run on	The user may be walking while favoring or putting more weight on either the left or right foot. If this walking pattern is natural, track the belt slightly off-center to the side opposite from the belt movement. See General Maintenance section on Treadbelt Tension. Adjust as necessary.
Motor is not responsive after pressing start	1. Reset power. If still no good contact service.
Treadmill will only achieve approximately 7mph but shows higher speed on display	This indicates motor should be receiving power to operate. Do not use an extension cord. If an extension cord is required it should be as short as possible and heavy duty 16-gauge minimum, low voltage. Contact an electrician or your dealer. A minimum of 120 volt AC current is required.
Treadmill trips on board 20 amp circuit	High belt/ deck friction. See General Maintenance section on cleaning the deck. If cleaning doesn't prevent this from reoccurring, check to see if there is significant wear of the deck. If so, the deck may need to be flipped if it is on its original side.
Computer shuts off when console is touched (on a cold day) while walking/running	Treadmill may not be grounded. Static electricity is "crashing" the computer. Refer to Grounding Instructions
Circuit breaker trips, but not the treadmill circuit breaker.	Check that the treadmill is the only object in the circuit. See "Important Electrical Information" in the front of this manual for more details.

TRAINING GUIDELINES

EXERCISE

Exercise is one of the most important factors in the overall health of an individual. Listed among its benefits are:

- Increased capacity for physical work (strength endurance)
- Increased cardiovascular (heart and arteries/veins) and respiratory efficiency
- Decreased risk of coronary heart disease
- Changes in body metabolism, e.g. losing weight
- Delaying the physiological effects of age
- Physiological effects, e.g. reduction in stress, increase in self-confidence, etc.

BASIC COMPONENTS OF PHYSICAL FITNESS

There are four all-encompassing components of physical fitness and we need to briefly define each and clarify its role.

Strength is the capacity of a muscle to exert a force against resistance. Strength contributes to power and speed and is of great importance to a majority of sports people.

Muscular Endurance is the capacity to exert a force repeatedly over a period of time, e.g. it is the capacity of your legs to carry you 10 Km without stopping.

Flexibility is the range of motion of a joint. Improving flexibility involves the stretching of muscles and tendons to maintain or increase suppleness, and provides increased resistance to muscle injury or soreness.

Cardio-respiratory endurance is the most essential component of physical fitness. It is the efficient functioning of the heart and lungs.

AEROBIC FITNESS

The largest amount of oxygen that you can use per minute during exercise is called your maximum oxygen uptake (MVo₂). This is often referred to as your aerobic capacity.

The effort that you can exert over a prolonged period of time is limited by your ability to deliver oxygen to the working muscles. Regular vigorous exercise produces a training effect that can increase your aerobic capacity by as much as 20 to 30%. An increased MVO₂ indicates an increased ability of the heart to pump blood, of the lungs to ventilate oxygen and of the muscles to take up oxygen.

Anaerobic Training

This means “without oxygen” and is the output of energy when the oxygen supply is insufficient to meet the body’s long-term energy demands. (For example, 100-meter sprint).

The Training Threshold

This is the minimum level of exercise which is required to produce significant improvements in any physical fitness parameter.

Progression

As you become fitter, a higher intensity of exercise is required to create an overload and therefore provide continued improvement.

Overload

This is where you exercise at a level above that which can be carried out comfortably. The intensity, duration and frequency of exercise should be above the training threshold and should be gradually increased as the body adapts to the increasing demands. As your fitness level improves, so the training threshold should be raised.

Working through your program and gradually increasing the overload factor is important.

Specificity

Different forms of exercise produce different results. The type of exercise that is carried out is specific both to the muscle groups being used and to the energy source involved.

There is little transfer of the effects of exercise, i.e. from strength training to cardiovascular fitness. That is why it is important to have an exercise program tailored to your specific needs.

Reversibility

If you stop exercising or do not do your program often enough, you will lose the benefits you have gained. Regular workouts are the key to success.

WARM-UP

Every exercise program should start with a warm-up where the body is prepared for the effort to come. It should be gentle and preferably use the muscles to be involved later.

Stretching should be included in both your warm-up and cool-down, and should be performed after 3-5 minutes of low-intensity aerobic activity or callisthenic-type exercise.

Warm Down or Cool Down

This involves a gradual decrease in the intensity of the exercise session. Following exercise, a large supply of blood remains in the working muscles. If it is not returned promptly to the central circulation, pooling of blood may occur in the muscles.

Heart Rate

As you exercise, the rate at which your heart beats also increases. This is often used as a measure of the required intensity of exercise. You need to exercise hard enough to condition your circulatory system and increase your pulse rate, but not enough to strain your heart.

Your initial level of fitness is important in developing an exercise program for you. If you are starting off, you can get a good training effect with a heart rate of 110-120 beats per minute (BPM). If you are fitter, you will need a higher threshold of stimulation.

To begin with, you should exercise at a level that elevates your heart rate to about 65 to 70% of your maximum. If you find this is too easy, you may want to increase it, but it is better to lean on the conservative side.

As a rule of thumb, the maximum heart rate is 220 minus your age. As you increase in age, your heart, like other muscles, loses some of its efficiency. Some of its natural loss is won back as fitness improves.

The following table is a guide to those who are “starting fitness”.

Age	25	30	35	40	45	50	55	60	65
Target heart Rate									
10 Second Count	23	22	22	21	20	19	19	18	18
Beats per Minute	138	132	132	126	120	114	114	108	108

Pulse Count

The pulse count (on your wrist or carotid artery in the neck, taken with two index fingers) is done for ten seconds, taken a few seconds after you stop exercising. This is for two reasons: (a) 10 seconds is long enough for accuracy, and (b) the pulse count is to approximate your BPM rate at the time you are exercising. Since heart rate slows as you recover, a longer count isn't as accurate.

The target is not a magic number, but a general guide. If you have above-average fitness, you may work quite comfortably a little above that suggested for your age group.

The following table is a guide to those who are keeping fit. Here we are working at about 80% of the maximum.

Age	25	30	35	40	45	50	55	60	65
Target heart Rate									
10 Second Count	26	26	25	24	23	22	22	21	20
Beats per Minute	156	156	150	144	138	132	132	126	120

Don't push yourself too hard to reach the figures on this table. It can be very uncomfortable if you overdo it. Let it happen naturally as you work through your program. Remember, the target is a guide, not a rule, a little above or below is just fine.

Two final comments:(1) don't be concerned with day-to-day variations in your pulse rate, being under pressure or not enough sleep can affect it;(2) your pulse rate is a guide, don't become a slave to it.

ENDURANCE CIRCUIT TRAINING

Cardiovascular endurance, muscle, strength, flexibility and coordination are all necessary for maximum fitness. The principle behind circuit training is to give a person all the essentials at one time by going through your exercise program moving as fast as possible between each exercise. This increases the heart rate and sustains it, which improves the fitness level. Do not introduce this circuit training effect until you have reached an advanced program stage.

Body Building

Is often used synonymously with strength training. The fundamental principle here is OVERLOAD. Here, the muscle works against greater loads than usual. This can be done by increasing the load you are working against.

Patronization

This is the term used to vary your exercise program for both physiological and psychological benefits. In your overall program, you should vary the workload, frequency and intensity. The body responds better to variety and so do you. In addition, when you feel yourself getting “stale”, bring in periods of lighter exercise to allow the body to recuperate and restore its reserves. You will enjoy your program more and feel better about it.

Muscle Soreness

For the first week or so, this may be the only indication you have that you are on an exercise program. This, of course, does depend on your overall fitness level. A confirmation that you are on the correct program is a very slight soreness in most major muscle groups. This is quite normal and will disappear in a matter of days.

If you experience major discomfort, you may be on a program that is too advanced or you have increased your program too rapidly.

If you experience PAIN during or after exercise, your body is telling you something. Stop exercising and consult your doctor.

WHAT TO WEAR

Wear clothing that will not restrict your movement in any way while exercising. Clothes should be light enough to allow the body to cool. Excessive clothing that causes you to perspire more than you normally would while exercising, gives you no advantage. The extra weight you lose is body fluid and will be replaced with the next glass of water you drink. It is advisable to wear a pair of gym or running shoes or “sneakers”.

Breathing During Exercise

Do not hold your breath while exercising. Breathe normally as much as possible. Remember, breathing involves the intake and distribution of oxygen, which feeds the working muscles.

Rest periods

Once you start your exercise program, you should continue through to the end. Do not break off halfway through and then restart at the same place later on without going through the warm-up stage again.

The rest period required between strength training exercises may vary from person to person. This will depend mostly on your level of fitness and the program you have chosen. Rest between exercises by all means, but do not allow this to exceed two minutes. Most people manage with half-minute to one-minute rest periods.

STRETCHING

Stretching should be included in both your warm-up and cool-down, and should be performed after 3-5 minutes of low-intensity aerobic activity or callisthenic-type exercise. Movements should be performed slowly and smoothly, with no bouncing or jerking. Move into the stretch until slight tension, not pain, is felt in the muscle and hold for 20-30 seconds. Breathing should be slow, rhythmical and under control, making sure never to hold your breath.

HEAD ROLLS

Rotate your head to the right for one count, feeling the stretch up the left side of your neck. Next rotate your head back for one count, stretching your chin to the ceiling and letting your mouth open. Rotate your head to the left for one count, and finally, drop your head to your chest for one count.

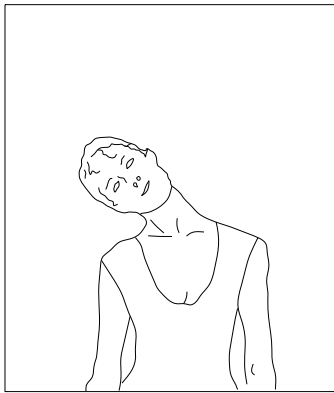

SHOULDER LIFTS

Lift your right shoulder up toward your ear for one count. Then lift your left shoulder up for one count as you lower your right shoulder.

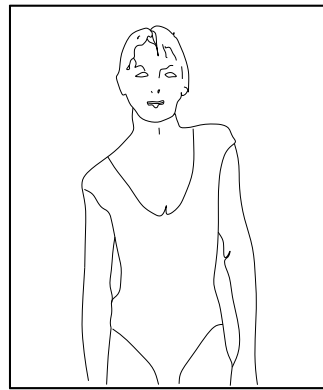

SIDE STRETCHES

Open your arms to the side and continue lifting them until they are over your head. Reach your right arm as far upward toward the ceiling as you can for one count. Feel the stretch up your right side. Repeat this action with your left arm.

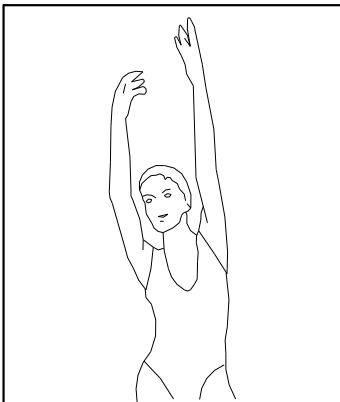

QUADRICEPS STRETCH

With one hand against a wall for balance, reach behind you and pull your right foot up. Bring your heel as close to your buttocks as possible. Hold for 15 counts and repeat with left foot up.

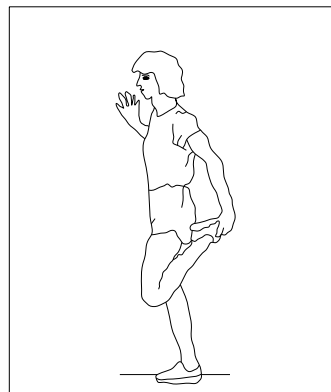

INNER THIGH STRETCH

Sit with the soles of your feet together with your knees pointing outward. Pull your feet as close into your groin as possible. Gently push your knees towards the floor. Hold for 15 counts.



TOUCHES

Slowly bend forward from your waist, letting your back and shoulders relax as you stretch toward your toes. Reach down as far as you can and hold for 15 counts.

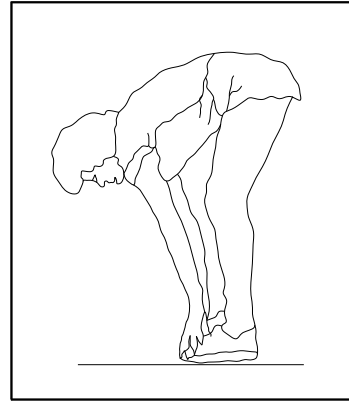

HAMSTRING STRETCHES

Sit with your right leg extended. Rest the sole of your left foot against your right inner thigh. Stretch as far as possible. Hold for 15 counts. Relax and then repeat with the left leg extended.

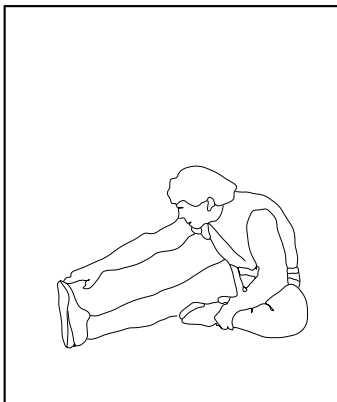

CALF / ACHILLES STRETCH

Lean against a wall with your left leg in front of the right and your arms forward. Keep toward your toe your right leg straight and the left foot on the floor then bend the left leg and lean forward by moving your hips toward the wall. Hold, then repeat on the other side for 15 counts.

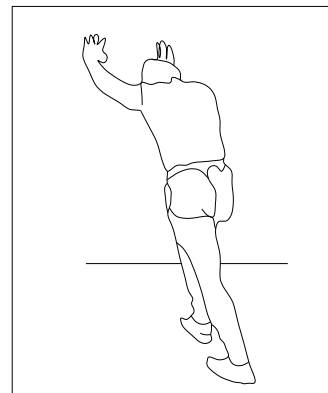

MANUFACTURER'S LIMITED WARRANTY

Dyaco Canada Inc. warrants all its Spirit treadmills for a period of time listed below, from the date of retail sale, as determined by a sales receipt. Dyaco Canada Inc.'s responsibilities include providing new or remanufactured parts, at Dyaco Canada Inc.'s option, and technical support to our independent dealers and servicing organizations. In the absence of a dealer or service organization, these warranties will be administered by Dyaco Canada Inc. directly to the facility. The warranty period applies to the following components:

Commercial (All Facility)

Frame	10 Years
Motor	5 Years
Deck	3 Years
Parts	3 Years
Labour	3 Years

This warranty is not transferable and is extended only to the original owner.

NORMAL RESPONSIBILITIES OF THE FACILITY

The facility is responsible for the items listed below:

1. The warranty registration can be completed online: Go to www.dyaco.ca/warranty.html and complete the online warranty registration
2. Proper use of the treadmill in accordance with the instructions provided in this manual.
3. Proper installation in accordance with instructions provided with the treadmill and with all local electric codes.
4. Proper connection to a grounded power supply of sufficient voltage, replacement of blown fuses, repair of loose connections or defects in facility wiring.
5. Expenses for making the treadmill accessible for servicing, including any item that was not part of the treadmill at the time it was shipped from the factory.
6. Damages to the treadmill finish during shipping, installation or following installation.
7. Routine maintenance of this unit as specified in this manual.

EXCLUSIONS

This warranty does not cover the following:

1. CONSEQUENTIAL, COLLATERAL, OR INCIDENTAL DAMAGES SUCH AS PROPERTY DAMAGE AND INCIDENTAL EXPENSES RESULTING FROM ANY BREACH OF THIS WRITTEN OR IMPLIED WARRANTY.
Note: Some areas do not allow the exclusion or limitation of incidental or consequential damages, so this limitation or exclusion may not apply to you.
2. Service call reimbursement to the facility. Service call reimbursement to the dealer that does not involve malfunction or defects in workmanship or material, for units that are beyond the warranty period, for units that are beyond the service call reimbursement period, for treadmills not requiring component replacement.
3. Damages caused by services performed by persons other than authorized Dyaco Canada Inc. service companies; use of parts other than original Dyaco Canada Inc. parts; or external causes such as corrosion, discoloration of paint or plastic, alterations, modifications, abuse, misuse, accident, improper maintenance, inadequate power supply, or acts of God.
4. Products with original serial numbers that have been removed or altered.
5. Products that have been: sold, transferred, bartered, or given to a third party.
6. Products that do not have a warranty registration card on file at Dyaco Canada Inc. Dyaco Canada Inc. reserves the right to request proof of purchase if no warranty record exists for the product.
7. THIS WARRANTY IS EXPRESSLY IN LIEU OF ALL OTHER WARRANTIES EXPRESSED OR IMPLIED, INCLUDING THE WARRANTIES OF MERCHANTABILITY AND/OR FITNESS FOR A PARTICULAR PURPOSE.
8. Warranties outside of Canada may vary. Please contact your local dealer or Dyaco Canada for details.

SERVICE

The sales receipt establishes the labour warranty period should service be required. If service is performed, it is in your best interest to obtain and keep all receipts. This written warranty gives you specific legal rights. Service under this warranty must be obtained by following these steps, in order:

1. Contact your selling authorized Spirit dealer or Dyaco Canada.
2. If you have any questions about your new product or questions about the warranty contact Dyaco Canada Inc. at 1-888-707-1880.
3. If no local service is available, Dyaco Canada Inc. will repair or replace the parts, at Dyaco Canada Inc.'s option, within the warranty period at no charge for parts. All transportation costs, both to our factory and upon return to the facility, are the responsibility of the facility. The facility is responsible for adequate packaging upon return to Dyaco Canada Inc. Dyaco Canada Inc. is not responsible for damages that occur during shipping. Make all freight damage claims with the appropriate freight carrier. DO NOT SHIP ANY UNIT TO OUR FACTORY WITHOUT A RETURN AUTHORIZATION NUMBER. All units arriving without a return authorization number will be refused.
4. For any further information, or to contact our service department by mail, send your correspondence to:

Dyaco Canada Inc.
5955 Don Murie Street
Niagara Falls, ON
L2G 0A9

Product features or specifications as described or illustrated are subject to change without notice. All warranties are made by Dyaco Canada.

dyaco

Please visit us online for information about our other brands and products manufactured and distributed by Dyaco Canada Inc.

SPIRIT

spiritfitness.ca

X XTERRA
FITNESS

xterrafitness.ca

UFC

dyaco.ca/UFC/UFC-home.html

agio.
life begins
outdoors.

agiocanada.ca

SOLE
FITNESS

solefitness.ca

EVERLAST

dyaco.ca/everlast.html

Cikada

cikada.ca

TRAINOR
SPORTS

trainorsports.ca

For more information, please contact Dyaco Canada Inc.
T: 1-888-707-1880 | 5955 Don Murie St., Niagara Falls, Ontario L2G 0A9 | sales@dyaco.ca

Dyaco Canada Inc. dyaco.ca