

**Owner's Manual**

**Model No.**  
16007301850

XT185

Assembly

Operation

Adjustments

Parts

Warranty

**CAUTION:**

Read and understand this manual before operating unit

# ***SPIRIT***



**Retain For Future Reference**

# TABLE OF CONTENTS

Product Registration .....	3
Important Safety Instructions .....	4
Important Electrical Instructions.....	6
Assembly Pack Checklist.....	8
Assembly Instructions .....	10
Folding Instructions .....	13
Operation of Your New Treadmill.....	14
Programmable features .....	17
Maintenance & Care .....	22
Service Checklist - Diagnosis Guide.....	26
Exploded View Diagram .....	27
Parts List .....	28
Manufacturer's Limited Warranty .....	31

# ***SPIRIT***

## **CONGRATULATIONS ON YOUR NEW TREADMILL**

Thank you for your purchase of this quality treadmill from Dyaco Canada Inc. Your new treadmill was manufactured by one of the leading fitness manufacturers in the world and is backed by one of the most comprehensive warranties available. Through your dealer, Dyaco Canada Inc, will do all we can to make your ownership experience as pleasant as possible for many years to come. The local dealership where you purchased this treadmill is your administrator for all warranty and service needs. Their responsibility is to provide you with technical knowledge and service personnel to make your experience more informed and any difficulties easier to remedy.

Please take a moment at this time to record the name of the dealer, their telephone number, and the date of purchase below to make any future, needed contact easy. We appreciate your support, and we will always remember that you are the reason that we are in business. Please go to [www.dyaco.ca/warranty](http://www.dyaco.ca/warranty) and complete the online warranty registration.

Name of Dealer: \_\_\_\_\_

Telephone Number of Dealer: \_\_\_\_\_

Purchase Date: \_\_\_\_\_

## ***Product Registration***

### **RECORD YOUR SERIAL NUMBER**

Please record the Serial Number of this fitness product in the space provided below.

Serial Number: \_\_\_\_\_

### **REGISTER YOUR PURCHASE**

Please visit us at [www.dyaco.ca/warranty](http://www.dyaco.ca/warranty) to register your purchase.

# Important Safety Instructions

**THIS UNIT IS INTENDED FOR HOUSEHOLD USE ONLY  
READ ALL INSTRUCTIONS BEFORE USING THIS TREADMILL**

**CAUTION:** Before starting any exercise program, it is recommended that you consult your physician.

**WARNING:** *Connect this unit to a properly grounded outlet only.*

**DANGER:** To reduce the risk of electric shock, always unplug the treadmill from the electrical outlet immediately after use and before cleaning.

## WARNING

**TO REDUCE THE RISK OF BURNS, FIRE, ELECTRIC SHOCK, OR INJURY TO PERSONS:**

### Grounding Instructions

This product must be grounded. If it should malfunction or break down, grounding provides a path of least resistance for electric current to reduce the risk of electric shock. This product is equipped with a cord having an equipment-grounding conductor and a grounding plug. The plug must be plugged into an appropriate outlet that is properly installed and grounded in accordance with all local codes and ordinances. See the diagram below for grounding methods.

Figure 1.  
Grounding methods

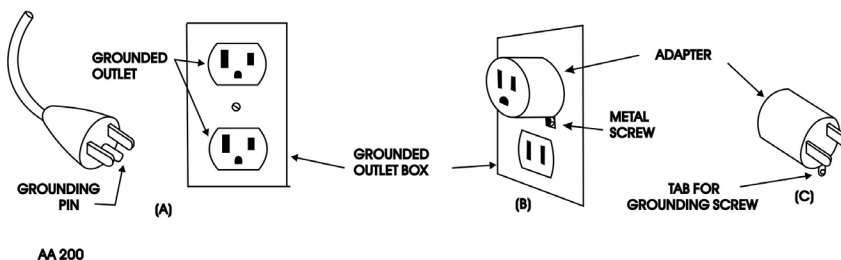

1. Use 110 Volt A.C. household current on a dedicated circuit.
2. It is the responsibility of the owner to ensure that all users of this treadmill are adequately informed of all warnings and precautions.
3. The use of an extension cord with this product is not recommended. If an extension cord is needed, use a short (less than 10 feet) heavy gauge (14 gauge or better) extension cord with a three-prong (grounded) plug and receptacle.
4. Never leave the treadmill unattended when plugged in. Remove the safety key and unplug the unit from the outlet when not in use and before removing or replacing parts.
5. Never operate the treadmill if it has a damaged cord or plug, if it is not working properly, if it has been dropped, damaged, or exposed to water. Never move the treadmill belt while the power is turned off.
6. Do not pull the treadmill by the power supply cord or use the cord as a handle. Keep the cord away from heated surfaces and open flames.
7. Fitness equipment must always be installed and used on a flat surface. Do not use outdoors or near water. Do not place the unit on a loose rug or uneven surface. It is recommended to use an equipment mat to prevent the unit from moving while it is being used, which could possibly scratch or damage the surface of your floor. It is recommended to have a minimum of 3 meters of safe clearance on all sides of the treadmill while in use.

8. Keep the treadmill indoors, away from moisture and dust. Do not put the treadmill in a garage, covered patio or near water.
9. Do not operate the treadmill where aerosol products are used or where oxygen is being administered.
10. Read, understand and test the emergency stop procedure before using the treadmill
11. Do not insert any objects into any openings.
12. Inspect and properly tighten all parts of the treadmill regularly.
13. Keep children and pets away from this equipment at all times while exercising.
14. Handicapped individuals should have medical approval and close supervision when using this treadmill.
15. Do not place your hands or feet under the treadmill. Always keep your hands and legs off of the treadmill when others are using it.
16. Never turn on the treadmill while standing on the tread belt. Always hold the handrails while using the treadmill. Always return the treadmill to the slowest speed to provide for safe dismount and low-speed restart.
17. To disconnect, turn all controls to the off position, then remove the plug from the outlet.
18. Do not attempt to raise, lower or move the treadmill until it is properly assembled. See page 14 on how to fold and move the treadmill. Care must be taken when lifting or moving the equipment, so as not to injure your back. Always use proper lifting techniques. You must not use any attachments that are not recommended by the manufacturer.
19. Use the treadmill only for its intended use as described in this manual. Do not use any attachments that are not recommended by the manufacturer.
20. User weight should not exceed 275 lbs (125 kgs).
21. Never allow more than one person on the treadmill at once.
22. Warm-up 5 to 10 minutes before each workout and cool down 5 to 10 minutes afterward. This allows your heart rate to gradually increase and decrease and will help prevent straining muscles.
23. Never hold your breath while exercising. Breathing should remain at a normal rate in conjunction with the level of exercise being performed.
24. Start your program slowly and very gradually increase your speed and distance.
25. Always wear suitable clothing and footwear while exercising. Do not wear loose-fitting clothing that could become entangled with the moving parts of your treadmill. Do not walk or jog barefoot, in stocking feet or loose-fitting shoes or slippers.
26. This treadmill is intended for in-home use only. Do not use the treadmill in any commercial, rental or institutional setting.

**▲WARNING: Before beginning any exercise program consult your physician. This is especially important for individuals over the age of 35 or persons with pre-existing health problems. Read all instructions before using any fitness equipment. We assume no responsibility for personal injury or property damage sustained by or through the use of this product.**

## SAVE THESE INSTRUCTIONS

# Important Electrical Instructions

## **WARNING!**

Route the power cord away from any moving part of the treadmill including the elevation mechanism and transport wheels.

**NEVER** remove any cover without first disconnecting AC power. If voltage varies by ten percent (10%) or more, the performance of your treadmill may be affected. **Such conditions are not covered under your warranty.** If you suspect the voltage is low, contact your local power company or a licensed electrician for proper testing.

**NEVER** expose this treadmill to rain or moisture. This product is NOT designed for use outdoors, near a pool or spa, or in any other high-humidity environment. The temperature specification is 40 degrees C, humidity is 95%, and non-condensing (no water drops forming on surfaces).

**Circuit breakers:** Avoid AFCI/GFCI circuit breakers if possible. These breakers may trip occasionally during use because of the high inrush currents from the treadmill drive motor. This condition is an issue with all treadmills and other products with large motors or electric heating elements like ovens.

New laws in your area may require these breakers. If you do have these breakers and outlets in your home and are experiencing nuisance tripping, you should check to see if there are any other devices plugged into the same circuit as fluorescent lights with electronic ballasts, coffee makers, space heaters, etc. Optimally the treadmill should be the only device plugged into the circuit.

Our treadmills have surge suppressors built in to help avoid nuisance tripping. We have tested several AFCI/GFCI breakers and outlets with our products that do not trip when only the treadmill is connected. Brands we have tested are Eaton (Cutler Hammer Series), Leviton (Smart lock pro) and Schneider Electric (Canadian home series).

**This product must be grounded.** If the treadmill should malfunction or break down, grounding provides a path of least resistance for electric current, reducing the risk of electric shock. This product is equipped with a cord having an equipment-grounding plug. The plug must be plugged into an appropriate outlet that is properly installed and grounded in accordance with all local codes and ordinances.

**DANGER - Improper connection of the equipment-grounding conductor can result in a risk of electric shock. Check with a qualified electrician or serviceman if you are in doubt as to whether the product is properly grounded. Do not modify the plug provided with the product if it will not fit the outlet; have a proper outlet installed by a qualified electrician.**

- **NEVER** operate this treadmill without reading and completely understanding the results of any operational change you request from the computer.
- Understand that changes in speed and incline do not occur immediately. Set your desired work level on the computer console and release the adjustment key. The computer will obey the command gradually.
- **NEVER** use your treadmill during an electrical storm. Surges may occur in your household power supply that could damage treadmill components.
- Use caution while participating in other activities while walking on your treadmill, such as watching television, reading, etc. These distractions may cause you to lose balance or stray from walking in the center of the belt, which may result in serious injury.
- **NEVER** mount or dismount the treadmill while the belt is moving. Spirit treadmills start at a very low speed, and it is unnecessary to straddle the belt during start-up. Simply standing on the belt during slow acceleration is proper after you have learned to operate the unit.
- Always hold on to a handrail or hand bar while making control changes (incline, speed, etc.). Do not use excessive pressure on the console control keys. They are precision set to function properly with little finger pressure. Pushing harder is not going to make the unit go faster or slower. If you feel the buttons are not functioning properly with normal pressure, contact your Spirit dealer.

## Safety Tether Cord

A safety tether cord is provided with this unit. It is a simple design that should be used at all times. It is for your safety should you fall or move too far back on the tread-belt. Pulling this safety tether cord will stop tread-belt movement. To Use:

### To Use:

1. Place the safety key into position on the oblong metal portion of the console control head. Your treadmill will not start and operate without this. Removing the safety key also secures the treadmill from unauthorized use.

2. Fasten the plastic clip onto your clothing securely to assure good holding power. **Note:** The magnet has strong enough power to minimize accidental, unexpected stopping. The clip should be attached securely to make certain it does not come off. Be familiar with its function and limitations. The treadmill will stop, depending on speed, with a one to two-step coast anytime the safety key is pulled off the console. Use the Stop/Pause switch in normal operation.

## Location Requirement

After assembling your treadmill, you'll need to make sure you've installed it in a safe area.

- We recommend that you leave an area of at least 20in on the front and sides of your machine. The front of the unit is where the motor is located.
- We recommend that you leave an area of at least 6ft behind the treadmill.
- Install your treadmill in an area where children and pets cannot access it.
- Always keep the area around your treadmill clear of furniture, exercise equipment and other debris.
- Do not install your treadmill on deeply padded, plush, or shag carpet.

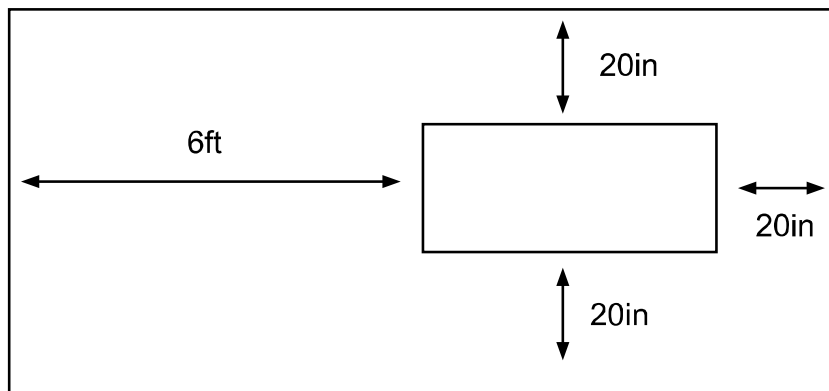

# ASSEMBLY PACK CHECKLIST

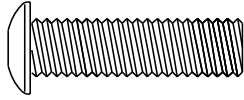

**#70.** 5/16" × 1" Button Head Socket Bolt (2 pcs)

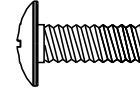

**#95.** M5 × 10mm Phillips Head Screw (6 pcs)



**#93.** 5/16" × 15mm Button Head Socket Bolt (12 pcs)

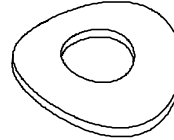

**#132.** 5/16" × 19 × 1.5T Curved Washer (2 pcs)

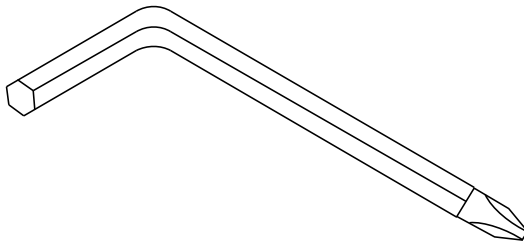

**#96.** Combination M5 Allen Wrench & Phillips Head Screwdriver

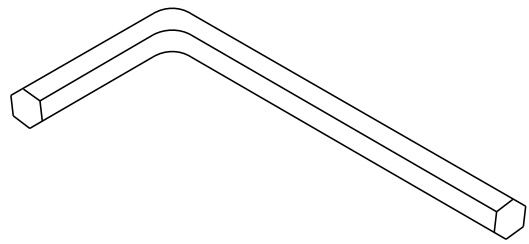

**#97.** M6\_L Allen Wrench

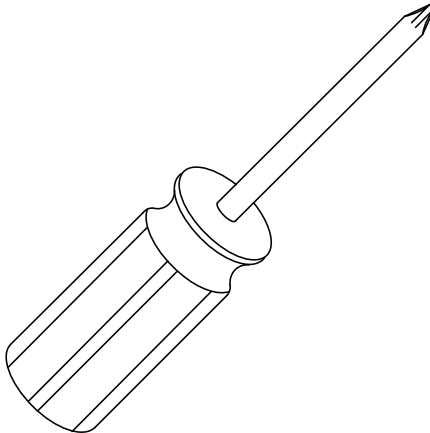

**#122.** Phillips Head Screwdriver

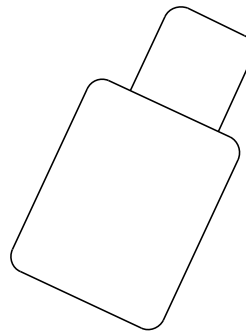

**#58.** Lubricant



# PRE-ASSEMBLY

**!!ATTENTION: IMPORTANT UNPACKING INSTRUCTIONS.  
PLEASE READ BEFORE UNPACKING YOUR FOLDING TREADMILL!!**

**WARNING:** There is a Velcro strap installed around the treadmill base that prevents the unit from unfolding accidentally during shipping. If this strap is not removed properly the treadmill could spring open unexpectedly and cause injury if someone is standing near the unit when the strap is removed.

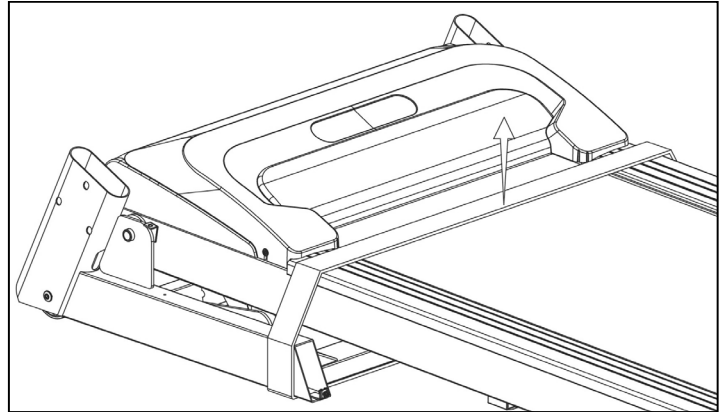

To ensure your personal safety during removal of the shipping strap please make sure the treadmill is positioned flat on the ground, in the orientation it would be in if you were using the treadmill. Do not turn the treadmill up on its side while removing the shipping strap. This could cause the unit's folding mechanism to spring open. If the end of the Velcro strap (that you need to grab to remove it) happens to be under the treadmill deck, reach under the deck to grab it, but do not tilt the treadmill up to gain access to the strap end.

1. Cut the straps, then lift the box over the unit and unpack.
2. Carefully remove all parts from the carton and inspect for any damage or missing parts. If parts are damaged or missing, contact your dealer immediately.
3. Locate the hardware package. Remove the tools first.
4. Remove the hardware for each step as needed to avoid confusion. The numbers in the instructions that are in parenthesis (#) are the item number from the assembly drawing for reference.

**Note:** Once your treadmill is fully assembled, be sure to check the belt lubrication before initial use by completing the following steps:

1. Ensure that your machine is off and that the power cord is unplugged to minimize the risk of injury.
2. Use one hand to hold the treadmill belt up just enough so you can use your other hand to reach between the belt and the deck. Verify that lubrication is present.

If lubrication is present, you may continue normal use. If lubrication is not present, please follow the steps to lubricate your treadmill belt using approved treadmill belt lubricant.



### STEP 3

Insert the **Right and Left Uprights (4) and (5)** into the **Frame Base (2)** and use the **Combination M5 Allen Wrench & Phillips Head Screwdriver (96)** to tighten the 8 pcs **5/16" × 15m/m Button Head Socket Bolt (93)**.

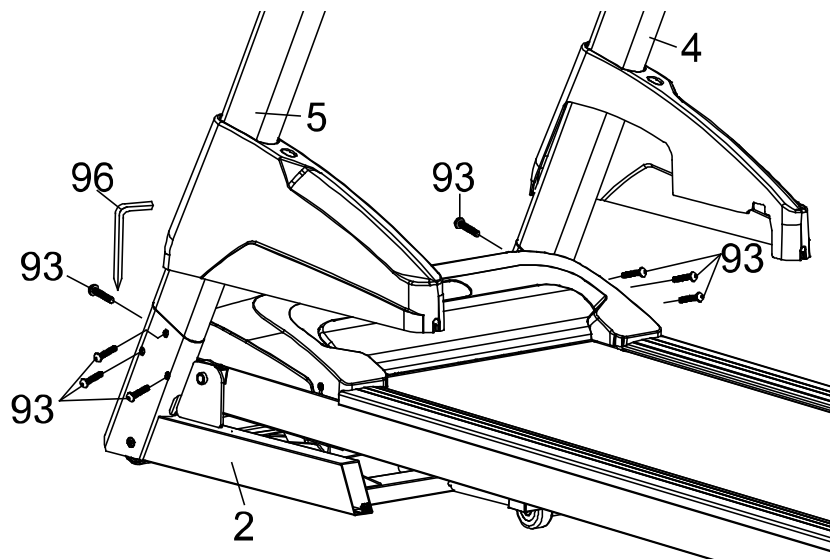

### STEP 4

Install the **Frame Base Covers (L) and (R), (42) and (43)**, on the **Frame Base (2)** and secure with 6 pcs **5 × 10m/m Phillips Head Screw (95)** using the **Phillips Head Screwdriver (122)**.

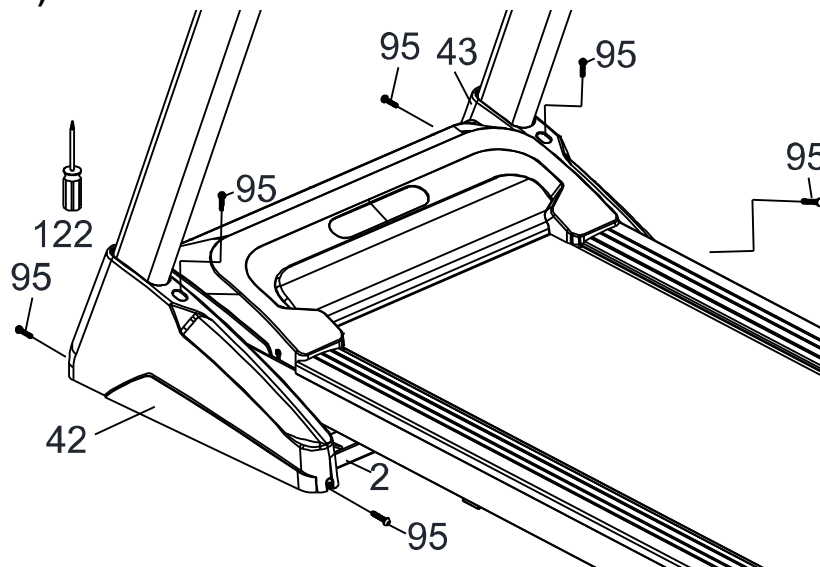

## STEP 5

Connect the **Computer Cable (Middle) (38)** and the **Computer Cable (Upper) (37)**.

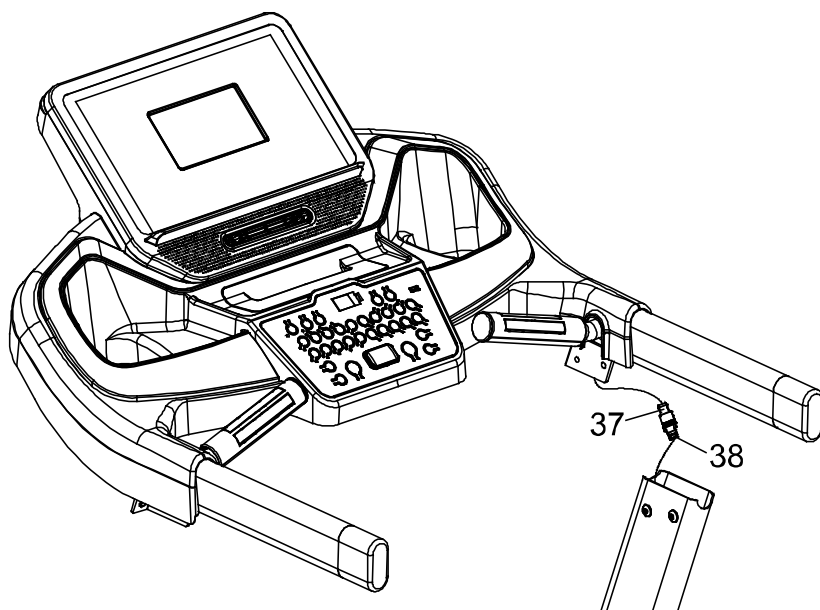

## STEP 6

Insert the **Console Assembly (40)** into the **Right and Left Uprights (4) and (5)** and secure with the 4pcs **5/16" × 15mm Button Head Socket Bolt (93)** with 2pcs of **Ø5/16" × 19 × 1.5T Curved Washers (132)** and using 2pcs of **5/16" × 1" Button Head Sock Bolts (70)** by using the **M6 L Allen Wrench (97)**.

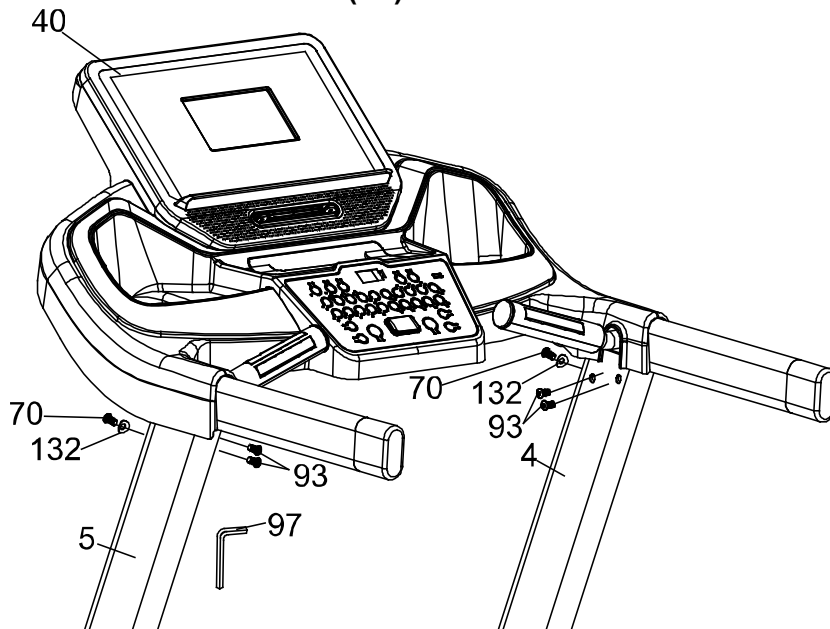

**NOTE:** Please Tighten All Screws After All Components Have Been Assembled.

**CAUTION:** Do not attempt to move the unit unless it is in the folded and locked position. Remove the power cord from the front of the unit to avoid possible damage. Use both handrails to maneuver the unit to the desired position.

# Folding Instructions

## ■ Folding Your Treadmill

Lift the deck until the latch is in place.

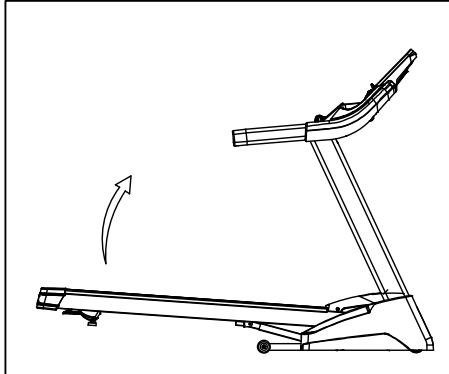

## ■ Unfolding Your Treadmill

Push running deck forward with left hand and pull the release lever downward with right hand.

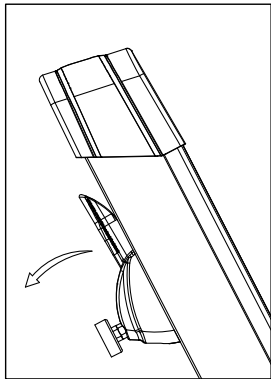

Gently lower the deck to the floor, supporting the deck with a hand.

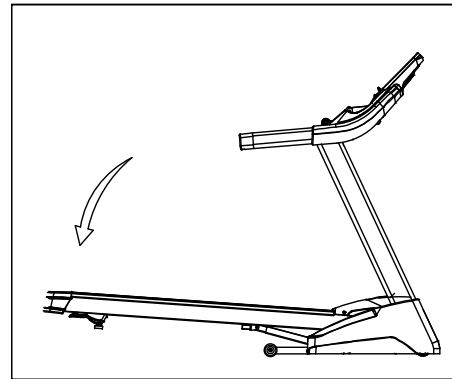

## Transportation Instructions

The treadmill is equipped with four transport wheels. After folding, simply roll the unit away. No need to tilt.

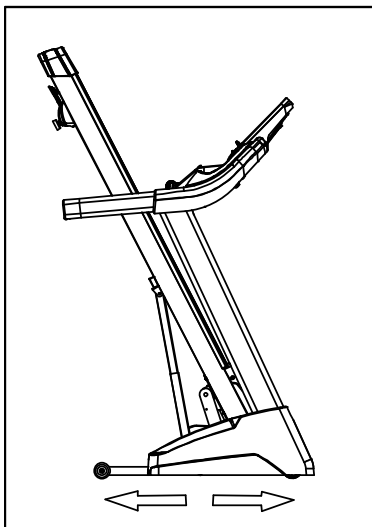

# OPERATION OF YOUR TREADMILL

## GETTING FAMILIAR WITH THE CONTROL PANEL

### CONSOLE



### Quick Start

1. Press and release the **Start key** to wake the display up (if not already on).  
Note: Installing the tether key will also wake up the console.
2. Press and release the **Start key** to begin belt movement, at 0.5mph, then adjust to the desired speed using the **Speed + / -** or **Fast/Slow** keys (console or handrail). You may also use the **Direct Speed** key, then 1 through 10 to adjust the speed.
3. To adjust the speed, press and hold the **Speed Up / Down keys** (console or remote handlebar buttons) to achieve the desired speed. You may also adjust to the desired speed by pressing **Direct Speed** and then 1 through 10.
4. To adjust the Incline level, press and hold the **Incline Up/ Down keys** (console or remote handlebar buttons) to achieve the desired gradient. You may also adjust to the desired incline by pressing the **Direct Incline key** and then 0 through 10.
5. To stop the tread-belt press and release the **Stop** key.

# FEATURES

## Direct Speed & Incline Buttons

You are able to set your speed and incline setting quickly by pressing the buttons on the console. Simply choose the desired speed and/or incline level from the console and the treadmill will automatically adjust to that level. This saves time because you don't have to press and hold or hold a button down until reaching the desired value.

## Console

The console will display Pace, Calories burned, Time (elapsed or countdown), Distance travelled, Pulse, Speed, Incline, Program Name, number of Laps completed, and Segment Time. There is also a Speed & Incline profile graph that lets you see how hard you have worked and how challenging the upcoming segments will be.

## Pause / Stop / Preset

1. When the treadmill is running the pause feature may be utilized by pressing the red **Stop** key once. This will slowly decelerate the tread-belt to a stop. The incline will go to zero percent. The Time, Distance and Calorie readings will hold while the unit is in pause mode. After 5 minutes the display will reset and return to the start-up screen.
2. To resume your exercise, when in Pause mode, press the **Start** key. The speed and incline will return to their previous settings.

**Note:** Pause is executed when the Stop button is pressed once. If the Stop key is pressed a second time, the program will end, and a workout summary will be displayed. If the Stop button is pressed a third time, the console will return to the idle mode (start-up) screen. If the Stop button is held down for more than 3 seconds, the console will reset.

## Child Lock

Your machine is equipped with a child lock feature which disables the buttons on the console to prevent unauthorized use. To turn it on, press Child Lock, then the LED will light up. The treadmill will be in idle mode and cannot be operated. You must hold Child Lock for 3 seconds to unlock. After the LED light turns off, press START to operate.

## Dot Matrix Center Display

Twenty columns of boxes (10 high) indicate each segment of a workout. The boxes only show an approximate level (resistance) of effort. They do not necessarily indicate a specific value - only an approximate percent to compare levels of intensity. In Manual Operation the resistance dot matrix window will build a profile "picture" as values are changed during a workout.

## 1/4 Mile Kilometer Track

The 1/4-mile track (one lap) will be displayed around the dot matrix window. The flashing segment indicates your progress. Once the 1/4-mile (Metric - 0.4k) is complete this feature will begin again. The Lap track will move in a counterclockwise direction. There is a lap counter in the message window for monitoring your distance.

## Incline

- Incline may be adjusted any time after belt movement.
- Press and hold the +/- or Up/Down keys (console or handrail) to achieve the desired level of effort. You may also choose a more rapid increase/decrease by simply pressing the desired level on the console.
- The display will indicate incline percent increases in increments of 0.5 as adjustments are made.
- The incline will return to zero unless the main power switch or safety key is turned off while at a higher setting.

## Calorie Display

Displays the cumulative calories burned at any given time during your workout.

Note: This is only a rough guide used for comparison of different exercise sessions and is not to be used for medical purposes.

## Pulse Grip Feature

The Pulse (Heart Rate) window will display your current heart rate in beats per minute during the workout. You must use both stainless-steel sensors on the stationary grips for the heart rate transmitter chest strap to display your pulse. Pulse value displays anytime the upper display is receiving a Pulse signal. You may not use the Pulse Grip feature while in Heart Rate Programs.

**Note:** Refer to Important Safety Instructions (page 5) concerning Pulse Grip operation.

## Programming the Console

Each of the programs can be customized with your personal information and changed to suit your needs. Some of the information is necessary to ensure the readouts are correct. You will be asked for your Age and Weight. Entering your Age is necessary during the Heart Rate programs to ensure the correct predicted target heart rate zone. Entering your Weight aids in calculating a more correct Calorie reading. Although we cannot provide an exact calorie count, we do want to be as close as possible.

**CALORIE NOTE:** Calorie readings on every piece of exercise equipment, whether it is in a gym or at home, are only an estimate and tend to vary widely. They are meant only as a guide to monitor your progress from workout to workout.

## Entering a Program and Changing Settings

When you enter a program, by pressing the **Program** key, then **Enter** key, you have the option of entering your own personal settings. If you want to work out without entering new settings, then just press the **Start** key. This will bypass the programming of data and take you directly to the start of your workout. If you want to change the personal settings, then just follow the instructions in the Message Center.

If you start a program without changing the settings, the default or saved settings will be used.

**NOTE:** Age and Weight default settings will change when you enter a new number. So, the last Age and Weight entered will be saved as the new default settings. If you enter your Age and Weight the first time you use the treadmill, you will not have to enter it every time you work out unless either your Age or Weight change or someone else enters a different Age and Weight.



Each preset program has a maximum Speed and Incline level that is displayed when a desired workout is chosen. The maximum Speed and Incline that the particular program will achieve will be displayed in the Message Center.

## PROGRAMMABLE FEATURES

### SELECT AND START A PROGRAM

Press the desired program (Hill, Fat Burn, Cardio, Strength, HIIT) key. Press **Enter** to select the program. The display will prompt you through the programming or you can just press **Start** to begin the program with default values.

1. If **Enter** was pressed, the Message Center will now be blinking at a value, indicating your Age. Entering your correct age affects the heart rate Bar Graph Display and the Heart Rate programs. Use the **+ / - keys** to adjust, then press Enter. Your age determines your recommended maximum heart rate. Since the Bar Graph Display and the Heart Rate features are based on a percentage of your maximum heart rate, it is important to enter the correct age for these features to work properly.
2. The Message Center will now be blinking a value, indicating your Body Weight. Entering the correct body weight will affect the calorie count. Use the **+ / - keys** to adjust, then press **Enter**.  
**A note about the Calorie display:** No exercise machine can give you an exact calorie count because there are too many factors which determine the exact calorie burn for a particular person. Even if someone is the exact same body weight, age and height, their calorie burn may be very different from yours. The Calorie display is to be used as a reference only to monitor improvement from workout to workout.
3. The Message Center will be blinking a value, indicating Time. You may use any of the **+ / - keys** to adjust the time. After adjusting, or accepting the default, press **Enter**. (Note: You may press **Start** at any time during programming to start the program).
4. The Message Center will now be blinking the preset top speed of the selected program. Use the **Speed + / - keys** to adjust, then press **Enter**. Each program has various speed changes throughout; this allows you to limit the highest speed the program can reach.
5. The Message Center will be blinking at the preset top incline of the selected program. Use the **Incline + / - keys** to adjust, then press **Enter**. You are now done programming data and may press **Start** to begin your workout or **Enter** to go back to one level to change data entered in the programming phase.

# PRESET PROGRAMS

The treadmill has eight different programs that have been designed for a variety of workouts. These eight programs have factory preset work level profiles for achieving different goals.

## HILL

This program follows a triangle or pyramid type of gradual progression from approximately 10% of maximum effort (the level that you chose before starting this program) up to a maximum effort which lasts for 10% of the total workout time, then a gradual regression of resistance back to approximately 10% of maximum effort.

Incline: The deck elevation is a more gradual and sustained progression. The maximum elevation is in the middle of the workout and lasts for 10% of the duration.

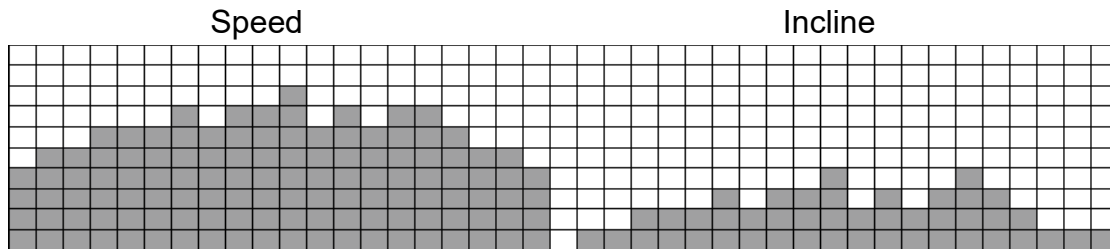

## FAT BURN

This program follows a quick progression up to the maximum resistance level (default or user input level) that is sustained for 2/3 of the workout. This program will challenge your ability to sustain your energy output for an extended period of time.

Incline: The deck elevation is a quick and sustained progression up to the maximum value (default or user input) for 90% of the workout duration.

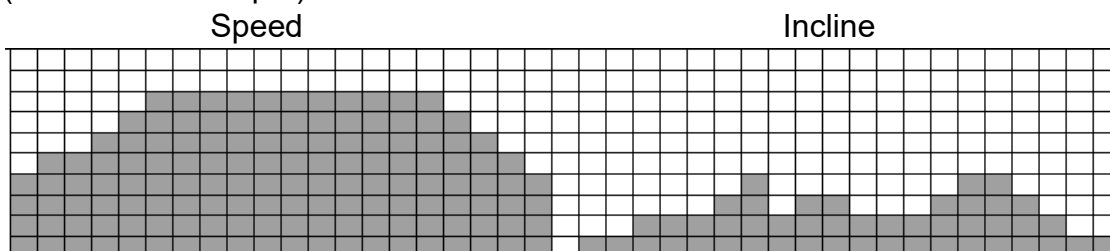

## CARDIO

This program presents a quick progression up to near maximum resistance level (default or user input level). It has slight fluctuations up and down to allow your heart rate to elevate, and then recover repeatedly, before beginning a quick cool down. This will build up your heart muscle and increase blood flow and lung capacity.

Incline: The elevation in this program is moderate. There are several elevation spikes at different points of the workout. Segments 15 are the maximum elevation for this program.

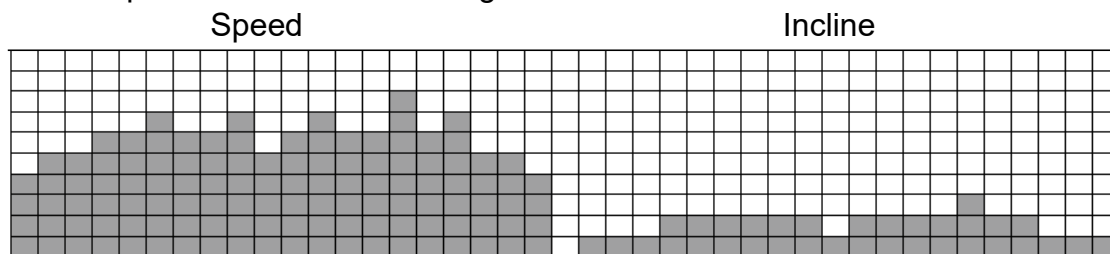

## STRENGTH

This program has a gradual progression of resistance up to 100% of maximum effort that is sustained for 25% of the workout duration. This will help build strength and muscular endurance in the lower body and glutes. A brief cool-down follows.

Incline: There is a quick climb to a moderate, sustained elevation that lasts the majority of the workout length.

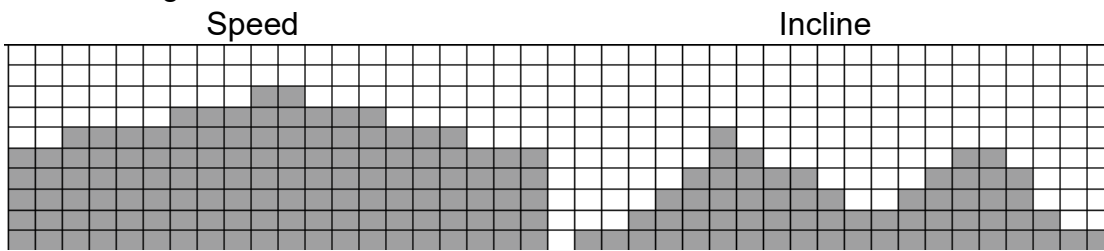

## HIIT

The HIIT program takes you through high levels of intensity followed by periods of low intensity. This program increases your endurance by depleting your oxygen level followed by periods of recovery to replenish oxygen. Your cardiovascular system gets programmed to use oxygen more efficiently this way. This program also forces your body to become more efficient due to spikes in heart rate, between recovery periods. This aids in heart rate recovery from intense activities.

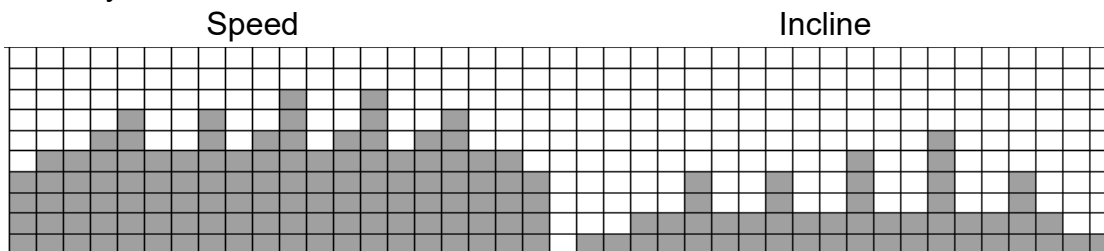

## PROGRAMS

### Fusion

1. Press the **PROGRAM** key to select the program. The screen will prompt you to program it. You can also press **Start** to start the program using the default values.
2. If **Enter** was pressed, the Message Center will now be blinking a value, indicating your Age. Entering your correct age affects the heart rate Bar Graph Display and the Heart Rate programs. Use the + / - keys to adjust, then press **Enter**. Your age determines your recommended maximum heart rate. Since the Bar Graph Display and the Heart Rate features are based on a percentage of your maximum heart rate, it is important to enter the correct age for these features to work properly.
3. The Message Center will now be blinking a value, indicating your Body Weight. Entering the correct body weight will affect the calorie count. Use the + / - keys to adjust, then press **Enter**. A note about the Calorie display: No exercise machine can give you an exact calorie count because there are too many factors which determine the exact calorie burn for a particular person. Even if someone is the exact same body weight, age and height, their calorie burn may be very different from yours.  
The Calorie display is to be used as a reference only to monitor improvement from workout to workout.
4. The Message Center will now be blinking the preset top speed of the selected program. Use

the **Speed** + / - keys to adjust, then press Enter. Each program has various speed changes throughout; this allows you to limit the highest speed the program can reach.

5. The Message Center will be blinking at the preset top incline of the selected program. Use the Incline + / - keys to adjust, then press **Enter**. You are now done programming data and may press Start to begin your workout or **Enter** to go back to one level to change data entered in the programming phase.
6. The message center will now flash the selected program's interval motion (preset to 10), adjust using the + / - key, and then press **Enter**.
7. The information center will now flash the interval of the selected program. (Preset to 1), use the + / - key to adjust, then press **Enter**.
8. You are now done programming data and may press **Start** to begin your workout or **Stop** to go back to one level to change data entered in the programming phase.

## 5K or 10K Program

1. Press **PROGRAM** to switch to 5K PROGRAM OR 10K PROGRAM. Press **Enter** to select a program. The display will prompt you to program the program, or you can simply press **Start** to start the program using the default values.
2. If **Enter** was pressed, the Message Center will now be blinking a value, indicating your Age. Entering your correct age affects the heart rate Bar Graph Display and the Heart Rate programs. Use the + / - keys to adjust, then press **Enter**. Your age determines your recommended maximum heart rate. Since the Bar Graph Display and the Heart Rate features are based on a percentage of your maximum heart rate, it is important to enter the correct age for these features to work properly.
3. The Message Center will now be blinking a value, indicating your Body Weight.
4. The message window displays "USE SPEED +/- KEYS TO ADJUST SPEED". Use **Speed** +/- to adjust speed, and then press **Enter**.
5. You are now done programming data and may press **Start** to begin your workout or **Stop** to go back to one level to change data entered in the programming phase.

## Countdown Mode

1. Press **PROGRAM** to select TARGET PROGRAM and then ENTER to display TARGET TIME. Press **PROGRAM** to switch to TARGET DISTANCE and TARGET CALORIES and press **ENTER** to confirm.
2. If **Enter** was pressed, the Message Center will now be blinking a value, indicating your Age. Entering your correct age affects the heart rate Bar Graph Display and the Heart Rate programs. Use the + / - keys to adjust, then press **Enter**. Your age determines your recommended maximum heart rate. Since the Bar Graph Display and the Heart Rate features are based on a percentage of your maximum heart rate, it is important to enter the correct age for these features to work properly.
3. The Message Center will now be blinking a value, indicating your Body Weight.
4. The message window displays the time, distance, and calorie presets to be adjusted, depending on the program you choose. Use the **Incline** + / - key to adjust, then press **Enter**.
5. You are now done programming data and may press **Start** to begin your workout or **Stop** to go back to one level to change data entered in the programming phase.

## Custom Workout Program

1. Press **PROGRAM** to select CUSTOM PROGRAM, then press **ENTER** to display CUSTOM1, then press **PROGRAM** to switch to CUSTOM2. If you want to select **ENTER** to confirm, note that the dot matrix display portion will have a single row of dots at the bottom (Unless there is a previously stored program). If there is a program stored under the button that is pressed, it will be retrieved. If not, you have the option of programming in your first name. The Message Window will display and flash the letter "A". To change it, press any **Up** key, then "B" will be displayed; if any **Down** key is pressed, the letter "Z" will be displayed. After selecting the appropriate letter, press **Enter**. The letter "A" will again be displayed and blinking. Repeat the procedure until all letters of your first name are programmed (7 characters maximum). When your name is displayed, press **Stop** and it will be stored under either CUSTOM 1 or CUSTOM2.
2. Next the Message Window is flashing Age. Use the **Incline + -** keys to adjust. Press **Enter**. This is a must to continue even if age is not adjusted.
3. The Message Window will now be blinking a body weight value. Enter your body weight and press **Enter**.
4. The Time Window and Message Window will now be blinking a Time value. Adjust the Time and press **Enter**.
5. The first column (segment) will now be blinking. Using the **Speed + -** or keys, adjust the speed level to your desired effort for the first segment then press Enter. The second column will now be blinking. Repeat the above process until all segments have been programmed. The first column will be blinking again. This is for incline programming. Repeat the above process to program all segments for incline.
6. Press the **Start** button to begin the workout and also save the program to memory.

Note: While in a User program, if you change the speed, all segment speeds from there on will also change.

Examples: If you increase your current speed by 1 mph, the remaining segment speeds will increase by 1 mph. If you decrease your current speed by 0.5 mph, the remaining segment speeds will decrease by 0.5 mph, etc.

# MAINTENANCE & CARE

## POST-WORKOUT MACHINE CARE

1. Store your machine according to the folding instructions when not in use.
2. Use a slightly damp cloth to clean areas where sweat or oil made contact with the machine.
3. Use a microfiber cloth to clean the touchscreen and remove unwanted oils and other things that may damage the screen.
4. Avoid leaving paper or other small debris in the cupholders.

## GENERAL CLEANING

Dirt, dust, and pet hair can block air inlets and accumulate on the running belt. Please vacuum underneath your treadmill on a monthly basis to prevent excess build-up of dirt that can get sucked up and get into the inner workings under the motor cover. Every other month, you should remove the motor cover and carefully vacuum out dirt and hair that may accumulate.



**UNPLUG THE POWER CORD BEFORE THIS TASK.**

## SANITIZING YOUR FITNESS EQUIPMENT

- Upholstered high-contact surfaces (hard plastics) can be sanitized using a 75% isopropyl alcohol solution and a clean, dry cloth. Spray surfaces to be sanitized and use a dry cloth to wipe clean. Allow surfaces to dry before using.
- For upholstered or soft-plastic surfaces, use a conditioner after sanitizing. Be sure to follow the instructions provided by the conditioner manufacturer to ensure proper use of the conditioner.
- Alternatively, you can make your own spray by mixing the proper ratio of isopropyl alcohol and distilled water to reach a 75% solution.

## TREAD-BELT TRACKING ADJUSTMENT

The treadmill is designed so that the tread-belt remains reasonably centered while in use. It is normal for some belts to drift near one side while in use, depending on a user's gait and if they favour one leg. But if during use the belt continues to move toward one side, adjustments are necessary.

### SETTING TREAD-BELT TRACKING

A 6mm Allen wrench is provided for this adjustment. Make tracking adjustments on the left side bolt. Set belt speed at 3 mph. Be aware that a small adjustment can make a dramatic difference which may not be apparent right away.

If the belt is too close to the left side, then turn the bolt only a 1/4 turn to the right (clockwise) and wait a few minutes for the belt to adjust itself. Continue to make 1/4 turn until the belt stabilizes in the center of the running deck.

If the belt is too close to the right side, turn the bolt counterclockwise. The belt may require periodic tracking adjustment depending on use and

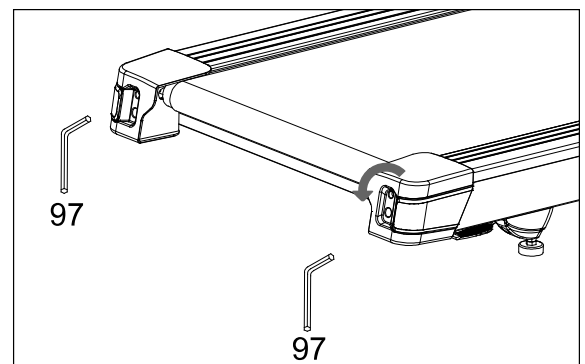
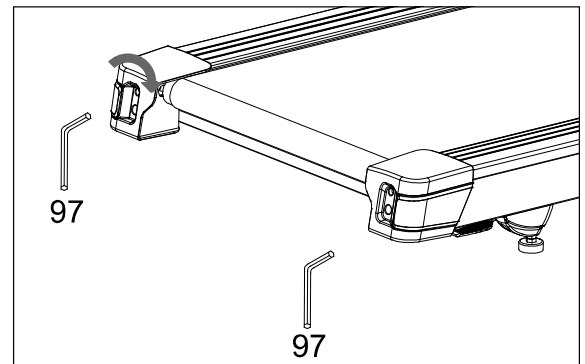

walking/running characteristics. Some users may affect tracking differently. Expect to make adjustments as required to center the tread-belt. Adjustments will become less of a maintenance concern as the belt is used. Proper belt tracking is an owner responsibility common with all treadmills.



**DAMAGE TO THE RUNNING BELT RESULTING FROM IMPROPER TRACKING / TENSION ADJUSTMENTS IS NOT COVERED UNDER THE WARRANTY**

### BELT ADJUSTMENTS

Tread-belt Tension Adjustment - Belt tension is not critical for most users. It is very important though for joggers and runners in order to provide a smooth, steady running surface. Adjustments must be made from the rear roller with the 6mm Allen wrench provided in the parts package. The adjustment bolts are located at the end of the step rails as shown in the diagram below.

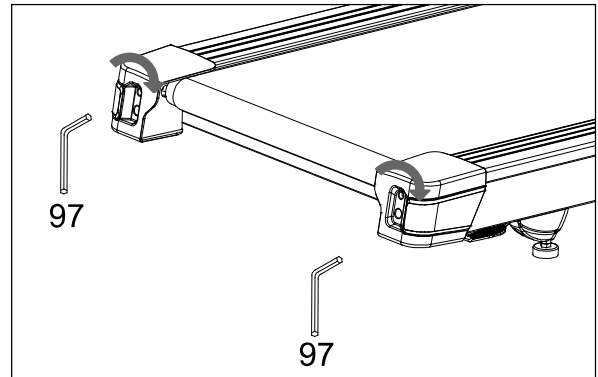

Tighten the rear roller enough to prevent slippage at the front roller. Turn the tread-belt tension adjusting bolts 1/4 turn each and inspect for proper tension by walking on the belt and making sure it is not slipping or hesitating with each step. When an adjustment is made to the belt tension, you must be sure to turn the bolts on both sides evenly or the belt could start tracking to one side instead of running in the middle of the deck.

**DO NOT OVERTIGHTEN** – Over-tightening will cause belt damage and premature bearing failure. If you tighten the belt a lot and it still slips, the problem could actually be the drive belt - located under the motor cover - that connects the motor to the front roller. If that belt is loose it feels similar to the walking belt being loose. Tightening the motor belt should be done by a trained service person.

## DECK LUBRICATION PROCEDURE

To ensure the longevity and proper functioning of your treadmill, proper belt maintenance is required. You should regularly check between the treadmill belt and the top of the treadmill base for proper lubrication, and to ensure that no dirt or debris has become trapped. Keeping the deck clean and lubricated at the recommended intervals ensures the longest life possible for your unit. Should lubrication dry out, or dirt become trapped, the friction between the belt and deck increases. Increased friction places undue stress on the drive motor, drive belt, and electronic motor control board which could result in catastrophic failure of these essential, expensive components. Failure to clean and lubricate the deck at regular intervals may void the warranty.

As a part of your routine maintenance schedule, belt lubrication and cleaning should be performed every 90 days, after 90 hours of use, or earlier if you notice that the deck is dry or dirty. Please also be sure to check belt lubrication before first use.

Do not lubricate with anything other than Spirit Fitness-approved lubricant. Your treadmill comes with one tube of treadmill belt lubricant.

### To lubricate your treadmill belt:

1. Ensure that your machine is off and unplugged to minimize the risk of injury.
2. Reach between the belt and the top of the treadmill base to verify that lubrication is present.
3. While kneeling beside your treadmill deck, use one hand to hold the treadmill belt up and away from the treadmill base just enough so you can use your other hand to reach the lubrication underneath.
4. Starting about 1 foot from the motor cover, begin applying ½ of your lubricant bottle in a long “S” pattern about 4-6” from one edge.
5. Repeat steps 3 and 4 on the opposite side using the remaining ½ of the lubricant bottle.
6. Plug the unit power cord back in and turn the power switch back on.
7. Walk on the belt at a moderate speed for 5 minutes to evenly distribute the lubricant along the treadmill belt and deck.
8. Your treadmill belt is now lubricated. Normal use can resume.

### Regularly check belt lubrication by completing the following steps:

1. Ensure that your machine is off and that the power cord is unplugged to minimize the risk of injury.
2. Reach between the running belt and the top of the treadmill base to verify that lubrication is present.

## BELT AND DECK CLEANING & CALIBRATION PROCEDURE

### Belt & Deck Cleaning

To clean your treadmill belt:

1. Ensure that your machine is off and that the power cord is unplugged to minimize the risk of injury.
2. Grab one edge of the treadmill belt and lift slightly to expose the area between the top of the treadmill base and the running belt.
3. Do a visual check for any dirt or debris accumulation.
4. Should dirt and debris be present, slide a towel or cleaning cloth between the treadmill belt and the top of the treadmill base until you can grasp one end on each side. (The cleaning cloth should be longer than the running belt is wide to achieve this.)
5. Using both hands, drag the cleaning cloth up and down the length of the treadmill base 1-2 times.
6. For excessive dirt accumulation, rotate the belt halfway, and repeat step 5. Continue until your cleaning cloth is no longer picking up any dirt.
7. Remove the cleaning cloth from the treadmill before plugging it back in.

### Calibration Procedure

1. Remove the Safety Key.
2. Press and hold **Start** and **Speed +** buttons and at the same time replace the Safety Key. Continue to hold **Start** and **Speed** keys until the window displays “Factory settings”, then press the **Enter** key.
3. You will now be able to set the display to show Metric or English settings (Miles vs. Kilometers). To do this, press the **incline +/-** key to show which you want, then press **Enter** (The maximum speed value is displayed in the speed window, and the maximum elevation value is displayed in the incline window.)
4. Grade return – On (This allows the incline to return to zero when **the Stop** button is pressed. For sale in Europe, EU standards require this to be off)
5. Press the **Start** button to begin calibration. The process is automatic; the speed will start up without warning, so do not stand on the belt.



## Engineering Mode Menu

The console has built-in maintenance/diagnostic software. The software will allow you to change the console settings from English to Metric and turn off the beeping of the speaker when a key is pressed for example. To enter the Engineering Mode Menu, press and hold down the **Start**, **Stop** and **Enter** keys. Keep holding the keys down for about 5 seconds and the Message Center will display Engineering Mode Menu. Press the **Enter** key to access the menu below:

1. Key Test (Will allow you to test all the keys to make sure they are functioning)
2. Display Test (Tests all the display functions)
3. Functions (Press Enter to access settings and Speed + or- arrow to scroll)
  - Sleep Mode (Turn on to have the console power down automatically after 15 minutes of inactivity)
  - Pause Mode (Turn on to allow 5 minutes of pause, turn off to have the console pause indefinitely)
  - Maintenance (Reset lube message and odometer readings)
  - Units (Sets the display to readout in English or Metric display measurements)
  - Key Tone (Turns off the speaker so no beeping sound is heard)
  - BEEP (After closing, there is no sound for key operation)
4. Child Lock (Allows you to lock the keypad so no unauthorized use of the machine is allowed. When the child lock is enabled, the console will not allow the keypad to operate unless you press and hold the Child Lock buttons for 3 seconds to unlock the console.)
5. Exit

# SERVICE CHECKLIST - DIAGNOSIS GUIDE

Before contacting your dealer for aid, please review the following information. It may save you both time and expense. This list includes common problems that may not be covered under the treadmill's warranty.

<b>PROBLEM</b>	<b>SOLUTION/CAUSE</b>
The display does not light	<ol style="list-style-type: none"> <li>1. The circuit breaker on the front grill tripped. Push the circuit breaker in until it locks.</li> <li>2. Plug is disconnected. Make sure the plug is firmly pushed into 115 VAC wall outlet.</li> <li>3. The breaker panel circuit breaker may be tripped.</li> <li>4. Treadmill defect. Contact your Spirit Fitness dealer.</li> </ol>
Tread-belt does not stay centered The treadmill belt hesitates when walking/running on	The user may be walking while favouring or putting more weight on either the left or right foot. If this walking pattern is natural, track the belt slightly Off-center to the side opposite from the belt movement. See the General Maintenance section on Tread-belt Tension Adjust as necessary.
The motor is not responsive after pressing the start	<ol style="list-style-type: none"> <li>1. If the belt moves but stops after a short time and the display shows "E1", run calibration.</li> <li>2. If you press Start and the belt never moves, then the display shows E1, contact service.</li> </ol>
The treadmill will only achieve approximately 7 mph but shows higher speed on display	This indicates the motor should be receiving power to operate. Low AC voltage to the treadmill. Do not use an extension cord. If an extension cord is required, it should be as short as possible heavy-duty 16 gauge minimum. Low voltage. Contact an electrician or your Spirit Fitness dealer. A minimum of 110-volt AC current is required.
Tread-belt stops quickly/suddenly when the tether cord is pulled	High belt/deck friction. See the Maintenance & Care section on cleaning the deck.
Treadmill trips on board 15-amp circuit	High belt/deck friction. See the Maintenance & Care section.
The computer shuts off the console is touched (on a cold day) while walking/running	The treadmill may not be grounded. Static electricity is "crashing" the computer. Refer to Grounding Instructions.
House circuit breaker trips, but not the treadmill circuit breaker	Check that the treadmill is the only object in the circuit. See "Important Electrical Information" at the front of this manual for more details.

# EXPLODED VIEW DIAGRAM

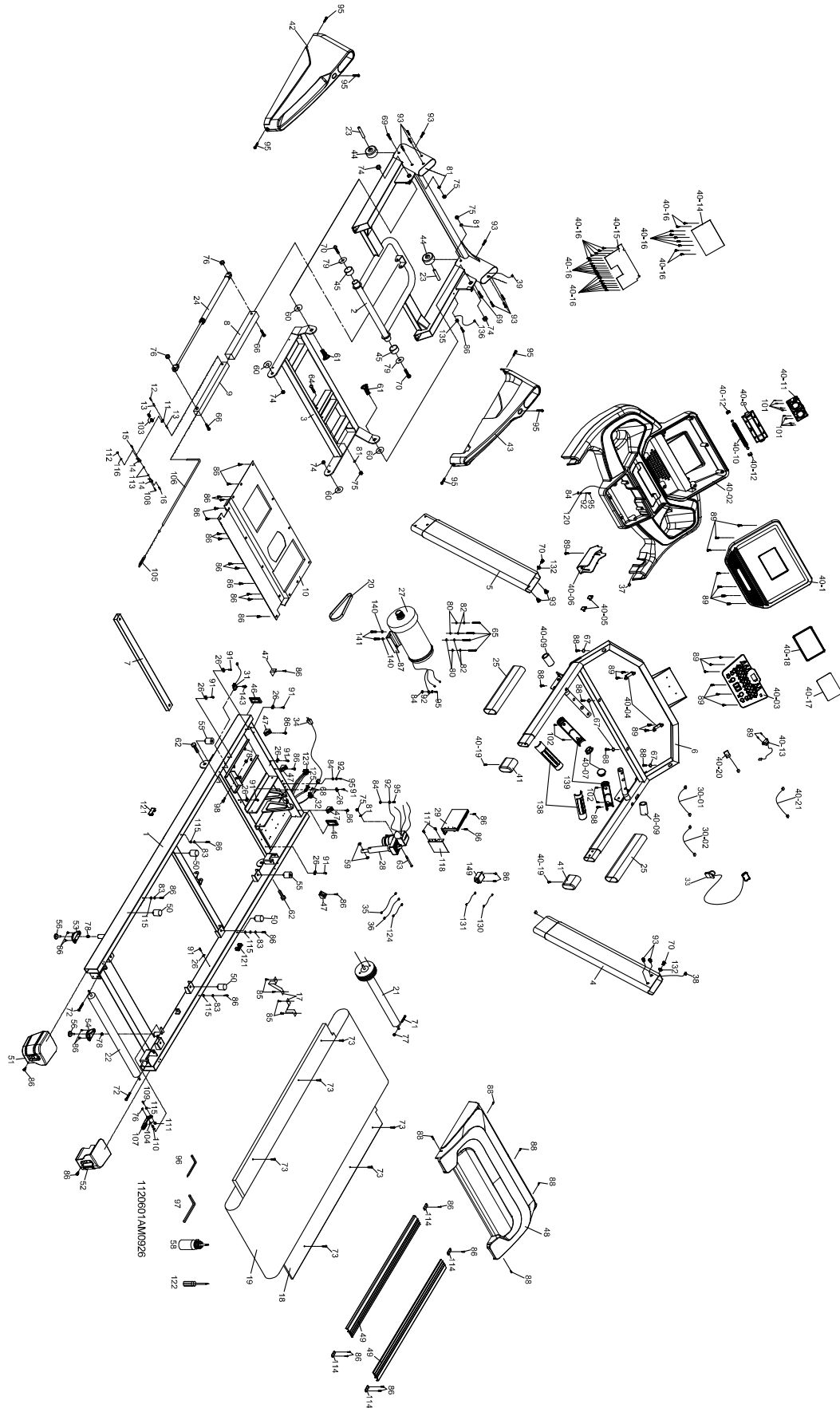

# PARTS LIST

Key	Part Description	Q'ty
1	Main Frame	1
2	Frame Base	1
3	Incline Bracket	1
4	Right Upright	1
5	Left Upright	1
6	Console Support	1
7	Deck Cross Brace	1
8	Outer Slide	1
9	Inner Slide	1
10	Motor Bottom Cover	1
11	Link	1
12	Link Shaft	1
13	Shaft Bushing	2
14	Fastening Bracket	2
15	Clevis Pin	1
16	Fastening Bushing	1
17	Belt Guide	2
18	Running Deck	1
19	Running Belt	1
20	Drive Belt	1
21	Front Roller W/Pulley	1
22	Rear Roller	1
23	Wheel Sleeve	2
24	Cylinder	1
25	PVC Handgrip	2
26	Wire Tie Mount	8
27	Drive Motor	1
28	Incline Motor	1
29	Motor Controller	1
30-01	1400m/m_Handpulse Wire (RED)	1
30-02	1400m/m_Handpulse Wire (WHITE)	1
31	Sensor W/Cable	1
32	Power Socket	1
33	Trapezoidal Safety Key	1
34	Power Cord	1
35	200m/m Connecting Wire (White)	1
36	200m/m_Connecting Wire (Black)	1
37	1100m/m_Computer Cable (Upper)	1
38	1100m/m_Computer Cable (Middle)	1
39	1200m/m_Computer Cable (Lower)	1
40	Console Assembly	1
41	Handgrip End Cap	2
42	Frame Base Cover (L)	1
43	Frame Base Cover (R)	1

<b>Key</b>	<b>Part Description</b>	<b>Q'ty</b>
44	Transportation Wheel(A)	2
45	Transportation Wheel(B)	2
46	Square End Cap	2
47	Motor Cover Anchor(D)	5
48	Motor Top Cover	1
49	Foot Rail	2
50	Cushion	4
51	Rear Adjustment Base (L)	1
52	Rear Adjustment Base (R)	1
53	Adjustment Foot Pad Cap (L)	1
54	Adjustment Foot Pad Cap (R)	1
55	Cushion	2
56	Adjustment Foot	2
58	Lubricant	1
59	Nylon Washer (A)	2
60	Nylon Washer (B)	4
61	1/2" × UNC12 × 1-1/4" _Carriage Bolt	2
62	1/2" × 1" _Hex Head Bolt	2
63	3/8" × 4" _Hex Head Bolt	1
64	3/8" × 92m/m _Hex Head Bolt	1
65	3/8" × 3/4" _Hex Head Bolt	4
66	5/16" × 2-3/4" _Button Head Socket Bolt	2
67	Ø1/4" × 19 × 1.5T _Flat Washer	4
68	3.5 × 16m/m _Tapping Screw	2
69	3/8" × 2" _Flat Head Socket Bolt	2
70	5/16" × 1" _Button Head Socket Bolt	4
71	M8 × 60m/m _Hex Head Bolt	1
72	M8 × 80m/m _Socket Head Cap Bolt	2
73	M8 × 30m/m _Flat Head Countersink Bolt	6
74	1/2" × 8.0T _Nylon Nut	4
75	3/8" × 7.0T _Nylon Nut	4
76	5/16" × 6.0T _Nylon Nut	3
77	M8 × 7T _Nylon Nut	1
78	3/8" × 7T _Nut	3
79	Ø8 × 35 × 1.5T _Flat Washer	2
80	Ø3/8" × Ø25 × 2.0T _Flat Washer	4
81	19 × 10 × 1.5T _Flat Washer	4
82	Ø10 × 2.0T _Split Washer	4
83	Ø25 × 20 × 16 × 5 × 1.1T × 4.5H _Concave Washer	4
84	M5 _Star Washer	4
85	4 × 12m/m _Sheet Metal Screw	4
86	Ø5 × 16m/m _Tapping Screw	40
87	Motor Bracket	1
88	3 × 16m/m _Tapping Screw	11
89	3.5 × 12m/m _Sheet Metal Screw	20

<b>Key</b>	<b>Part Description</b>	<b>Q'ty</b>
<b>91</b>	Ø3.5 × 16m/m_Tapping Screw	8
<b>92</b>	Ø5 × 1.5T_Split Washer	4
<b>93</b>	5/16" × 15m/m_Button Head Socket Bolt	12
<b>95</b>	M5 × 10m/m_Phillips Head Screw	10
<b>96</b>	M5_Allen Wrench & Phillips head Screwdriver	1
<b>97</b>	M6_L Allen Wrench	1
<b>98</b>	3/8" × 2" _Hex Head Bolt	1
<b>101</b>	3.5 × 40m/m_Sheet Metal Screw	8
<b>102</b>	3 × 12m/m_Tapping Screw	4
<b>103</b>	Dual Torsion-Spring	1
<b>104</b>	ChenChin Torsion-Spring	1
<b>105</b>	Steel Cable Tension Spring	1
<b>106</b>	Steel Cable	1
<b>107</b>	Release Lever	1
<b>108</b>	M3 × 10m/m_Phillips Head Screw	1
<b>109</b>	M5 × 20m/m_Phillips Head Screw	1
<b>110</b>	5/16" × 2" _Hex Head Bolt	1
<b>111</b>	M5 × 5.0T_Nylon Nut	1
<b>112</b>	M3 × 2.5T_Nut	1
<b>113</b>	Ø5 × Ø10 × 1T_Flat Washer	2
<b>114</b>	Ø5.5 × 27 × 60 × 1T × 2.5H_Concave Washer	4
<b>115</b>	Ø5 × Ø13 × 1.0T_Flat Washer	5
<b>116</b>	M3 × 1T_Split Washer	1
<b>117</b>	3 × 10m/m_Sheet Metal Screw	2
<b>118</b>	Controller Back Plate	1
<b>120</b>	500m/m_Console Ground Wire	1
<b>121</b>	Square End Cap	2
<b>122</b>	Phillips Head Screwdriver	1
<b>123</b>	AC Electronic Module	1
<b>124</b>	100m/m_Connecting Wire (Black)	1
<b>125</b>	Breaker	1
<b>130</b>	300m/m_Connecting Wire (White)	1
<b>131</b>	300m/m_Connecting Wire (Black)	1
<b>132</b>	Ø5/16" × 19 × 1.5T_Curved Washer	2
<b>135</b>	Wire Clamp	1
<b>136</b>	1000m/m_Ground Wire	1
<b>138</b>	Handpulse Sensor (w/o wire)	2
<b>139</b>	Handpulse Bottom Cover	2
<b>140</b>	Ø8 × 1.5T_Split Washer	2
<b>141</b>	M8 × P1.25 × 12m/m_Hex Head Bolt	2
<b>143</b>	5 × 19m/m_Tapping Screw	1
<b>149</b>	Filter	1

# MANUFACTURER'S LIMITED WARRANTY

## TREADMILL WARRANTY

Dyaco Canada Inc. warrants all its SPIRIT treadmills' parts, for a period of time listed below, from the date of retail sale, as determined by the sale receipt. Dyaco Canada Inc.'s responsibilities include providing new or remanufactured parts, at Dyaco Canada Inc.'s option, and technical support to our independent dealers and servicing organizations. In the absence of a dealer or service organization, these warranties will be administered by Dyaco Canada Inc. directly to a consumer. The warranty period applies to the following components:

Frame Weldments	Lifetime
Drive Motor	Lifetime
Deck	Lifetime
All Other Components	10 Years
Labour	1 Year
Cosmetic Items *	90 days

\*Cosmetic items including, but not limited to the following: grips, console overlays, and labels/decals.

## NORMAL RESPONSIBILITIES OF THE CONSUMER

This warranty applies only to products in ordinary household use, and the consumer is responsible for the items listed below:

1. The warranty registration can be completed online: Go to [www.dyaco.ca/warranty](http://www.dyaco.ca/warranty) and complete the online warranty registration.
2. Proper use of the treadmill in accordance with the instructions provided in this manual, including belt tracking.
3. Proper installation in accordance with instructions provided with the treadmill and with all local electric codes.
4. Proper connection to a grounded power supply of sufficient voltage, replacement of blown fuses, repair of loose connections or defects in house wiring.
5. Expenses for making the treadmill accessible for servicing, including any item that was not part of the treadmill at the time it was shipped from the factory.
6. Damages to the treadmill finish during shipping, installation or following the installation.
7. Routine maintenance of this unit as specified in this manual.

## EXCLUSIONS

This warranty does not cover the following:

1. CONSEQUENTIAL, COLLATERAL, OR INCIDENTAL DAMAGES SUCH AS PROPERTY DAMAGE AND INCIDENTAL EXPENSES RESULTING FROM ANY BREACH OF THIS WRITTEN OR ANY IMPLIED WARRANTY.

Note: Some areas do not allow the exclusion or limitation of incidental or consequential damages, so this limitation or exclusion may not apply to you.

2. Service call reimbursement to the consumer. Service call reimbursement to the dealer that does not involve malfunction or defects in workmanship or material, for units that are beyond the warranty period, for units that are beyond the service call reimbursement period, for treadmill not requiring component replacement, or treadmill not in ordinary household use.
3. Damages caused by services performed by persons other than authorized Dyaco Canada Inc. service companies; use of parts other than original Dyaco Canada Inc. parts; or external causes such as corrosion, discoloration of paint or plastic, alterations, modifications, abuse, misuse, accident, improper maintenance, inadequate power supply, or acts of God.
4. Products with original serial numbers that have been removed or altered.
5. Products that have been sold, transferred, bartered, or given to a third party.
6. Products that do not have a warranty registration card on file at Dyaco Canada Inc. Dyaco Canada Inc. reserves the right to request proof of purchase if no warranty record exists for the product.
7. THIS WARRANTY IS EXPRESSLY IN LIEU OF ALL OTHER WARRANTIES EXPRESSED OR IMPLIED, INCLUDING THE WARRANTIES OF MERCHANTABILITY AND/OR FITNESS FOR A PARTICULAR PURPOSE.
8. Product use in any environment other than a residential setting.
9. Warranties outside of North America may vary. Please contact your local dealer for details.

## SERVICE

Keep your bill of sale. The labour period is twelve (12) months from the date on the bill of sale. If service is performed, it is in your best interest to obtain and keep all receipts. This written warranty gives you specific legal rights. You may also have other rights that vary in different areas. Service under this warranty must be obtained by following these steps, in order:

1. Contact your selling authorized SPIRIT dealer.
2. If you have any questions about your new product or questions about the warranty contact Dyaco Canada Inc. at 1-888-707-1880.
3. If no local service is available, Dyaco Canada Inc. will repair the parts, at Dyaco Canada Inc.'s option, within the warranty period at no charge for parts. All transportation costs, both to our factory and upon return to the owner, are the responsibility of the owner. The owner is responsible for adequate packaging upon return to Dyaco Canada Inc. Dyaco Canada Inc. is not responsible for damages that occur during shipping. Make all freight damage claims with the appropriate freight carrier. DO NOT SHIP ANY UNIT TO OUR FACTORY WITHOUT A RETURN AUTHORIZATION NUMBER. All units arriving without a return authorization number will be refused.
4. For any further information, or to contact our service department by mail, send your correspondence to:

**Dyaco Canada Inc.**  
5955 Don Murie Street  
Niagara Falls, ON  
L2G 0A9

**Product features or specifications as described or illustrated are subject to change without notice. All warranties are made by Dyaco Canada Inc.**

# dyaco

Please visit us online for information about our other brands and products manufactured and distributed by Dyaco Canada Inc.

**SPIRIT**

[spiritfitness.ca](http://spiritfitness.ca)

**X** XTERRA

[xterrafitness.ca](http://xterrafitness.ca)

**UFC**

[dyaco.ca/UFC/UFC-home.html](http://dyaco.ca/UFC/UFC-home.html)

**SOLE**  
FITNESS

[solefitness.ca](http://solefitness.ca)

**EVERLAST**

[dyaco.ca/products/everlast.html](http://dyaco.ca/products/everlast.html)

 *Johnny G*  
by **SPIRIT**

[spiritfitness.ca/johnnyg.html](http://spiritfitness.ca/johnnyg.html)

**TRAINOR**  
**SPORTS**

[trainorsports.ca](http://trainorsports.ca)

For more information, please contact Dyaco Canada Inc.

T: 1-888-707-1880 | 5955 Don Murie St., Niagara Falls, Ontario L2G 0A9 | [sales@dyaco.ca](mailto:sales@dyaco.ca)

Dyaco Canada Inc. [dyaco.ca](http://dyaco.ca)