

## Owner's Manual

**Model No.**  
16207383950  
XBR95

- Assembly
- Operation
- Adjustments
- Parts
- Warranty

**CAUTION:**  
Read and  
understand this  
manual before  
operating unit

# SPIRIT



Retain For Future Reference

# TABLE OF CONTENTS

Product Registration.....	2
Important Safety Instructions.....	3
Important Electrical Instructions.....	5
Important Operation Instructions.....	5
Assembly Instructions.....	6
Setting Up Your Bike.....	11
About Your Machine & Using the Spirit+ App.....	12
Operation of Your Console.....	13
Programmable Features.....	16
Programs Intro.....	17
Using A Heart Rate Transmitter.....	25
Maintenance & Care.....	26
Exploded View Diagram.....	28
Parts List.....	29
Manufacturer's Limited Warranty.....	33

## **ATTENTION**

***This Recumbent Bike is intended for residential use only and is warranted for this application. Any other application voids this warranty in its entirety.***

# ***SPIRIT***

## **CONGRATULATIONS ON YOUR NEW FITNESS BIKE**

Thank you for your purchase of this quality fitness bike trainer from Dyaco Canada Inc. Your new bike was manufactured by one of the leading fitness manufacturers in the world and is backed by one of the most comprehensive warranties available. Through your dealer, Dyaco Canada Inc. will do all we can to make your ownership experience as pleasant as possible for many years to come. The local dealership where you purchased this bike is your administrator for all Dyaco Canada Inc. warranty and service needs. Their responsibility is to provide you with the technical knowledge and service personnel to make your experience more informed and any difficulties easier to remedy.

Please take a moment at this time to record the name of the dealer, their telephone number, and the date of purchase below to make any future needed contact easy. We appreciate your support, and we will always remember that you are the reason that we are in business. Please go to [www.dyaco.ca/warranty](http://www.dyaco.ca/warranty) and complete the online warranty registration.

Name of Dealer \_\_\_\_\_

Dealer Phone # \_\_\_\_\_

Purchase Date \_\_\_\_\_

## ***Product Registration***

### **RECORD YOUR SERIAL NUMBER**

Please record the Serial Number of this fitness product in the space provided below.

Serial Number \_\_\_\_\_

### **REGISTER YOUR PURCHASE**

Please visit us at [www.dyaco.ca/warranty](http://www.dyaco.ca/warranty) to register your purchase.

# Important Safety Instructions

When using electrical equipment, basic precautions should always be followed, including the following:

**WARNING** - Read all instructions before using this equipment.

**DANGER** - To reduce the risk of electric shock: Always unplug this equipment from the electrical outlet immediately after using and before cleaning.

**WARNING** - To reduce the risk of burns, fire, electric shock, or injury to persons, install the Upright Bike on a flat level surface with access to a 115-volt, 15-amp grounded outlet with only the Upright Bike plugged into the circuit.

**DO NOT USE AN EXTENSION CORD UNLESS IT IS A 14AWG OR BETTER, WITH ONLY ONE OUTLET ON THE END:**

- Equipment should never be left unattended when plugged in. Unplug from outlet when not in use, and before putting on or taking off parts.
- Do not operate under a blanket or pillow. Excessive heating can occur and cause fire, electric shock, or injury to persons.
- This equipment is not intended for use by persons with reduced physical, sensory or mental capabilities, or lack of experience and knowledge unless they have been given supervision or instruction concerning the use of the equipment by a person responsible for their safety.
- Use this equipment only for its intended use as described in this manual. Do not use attachments not recommended by the manufacturer.
- Never operate this equipment if it has a damaged cord or plugs, if it is not working properly, if it has been dropped or damaged, or dropped into water. Return the equipment to a service center for examination and repair.
- Do not carry this equipment by supply cord or use cord as a handle.
- Keep the cord away from heated surfaces.
- Never operate the equipment with the air openings blocked. Keep the air openings free of lint, hair, and the like.
- Never drop or insert any object into any opening.
- Do not use outdoors.
- Do not operate where aerosol (spray) products are being used or where oxygen is being administered.
- Connect this equipment to a properly grounded outlet only. See Grounding Instructions.
- The equipment is intended for household use.
- To disconnect, turn all controls to the off position, then remove the plug from the outlet.
- Do not operate equipment on deeply padded, plush or shag carpet. Damage to both carpet and equipment may result.
- Before beginning this or any exercise program, consult a physician. This is especially important for persons over the age of 35 or persons with pre-existing health conditions.
- Keep your hands away from all moving parts.
- The pulse sensors are not medical devices. Various factors, including the user's movement, may affect the accuracy of heart rate readings. The pulse sensors are intended only as exercise aids in determining heart rate trends in general.
- Do not attempt to use your equipment for any purpose other than for the purpose it is intended.
- Wear proper shoes. High heels, dress shoes, sandals or bare feet are not suitable for use on your equipment. Quality athletic shoes are recommended to avoid leg fatigue.
-

- Close supervision is necessary when this equipment is used by, on, or near children, invalids, or disabled persons.
- Keep children under the age of 13 away from this machine.
- **The Recumbent bike is not a medical device.**

**Please ensure that you review and adhere to the user weight restrictions and power requirements of your new machine. Failure to do so may result in serious injury or damage to your machine.**

**SAVE THESE INSTRUCTIONS - THINK SAFETY!**

# Important Electrical Instructions

## WARNING!

**NEVER** expose this unit to rain or moisture. This product is NOT designed for use outdoors, near a pool or spa, or in any other high-humidity environment. The operating temperature specification is 40 to 120 degrees Fahrenheit, and humidity is 95% non-condensing (no water drops forming on surfaces).

# Important Operation Instructions

- **NEVER** operate this unit without reading and completely understanding the results of any operational change you request from the computer.
- **NEVER** use your unit during an electrical storm. Surges may occur in your household power supply that could damage unit components. Unplug the unit during an electrical storm as a precaution.
- Understand that changes in resistance do not occur immediately. Set your desired resistance level on the computer console and release the adjustment key. The computer will obey the command gradually.
- Use caution while participating in other activities while pedalling on your Upright Bike; such as watching television, reading, etc. These distractions may cause you to lose balance which may result in serious injury.
- Do not use excessive pressure on console control keys. They are precision set to function properly with little finger pressure.

# WARNING DECAL REPLACEMENT

The decal shown below has been placed on the bike. If the decal is missing or illegible, please call our Customer Service Department toll-free at 1-888-707-1880 to order a replacement decal.

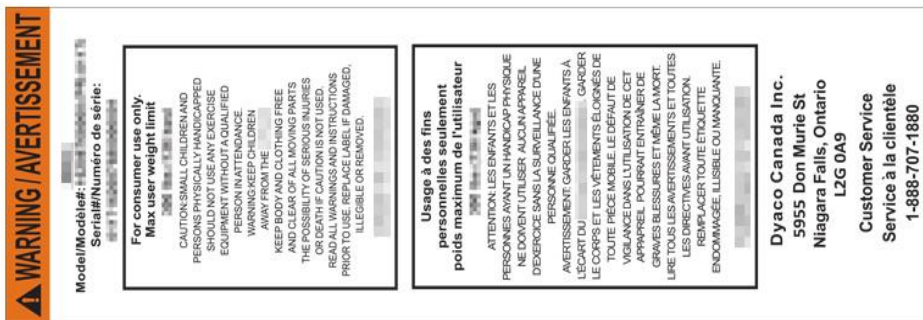

# ASSEMBLY INSTRUCTIONS

## PRE-ASSEMBLY

**!!ATTENTION: IMPORTANT UNPACKING INSTRUCTIONS.  
PLEASE READ BEFORE UNPACKING YOUR FOLDING UPRIGHT BIKE!!**

1. Using a razor knife (Box Cutter), cut the banding straps that wrap around the carton. Reach under the bottom edge of the carton and pull it away from the cardboard underneath, separating the staples that join the two together. Lift the box over the unit and unpack.
2. Carefully remove all parts from the carton and inspect for any damage or missing parts. If damaged parts are found, or parts are missing, contact your dealer immediately.
3. Locate the hardware package. The hardware is separated into four steps. Remove the tools first. Remove the hardware for each step as needed to avoid confusion. The numbers in the instructions that are in parenthesis (#) are the item number from the assembly drawing for reference.

## ASSEMBLY TOOLS

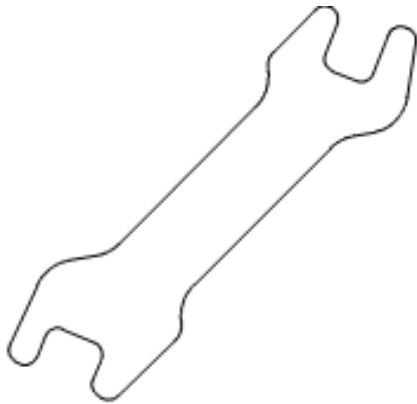

**#112.** 12/14mm Wrench

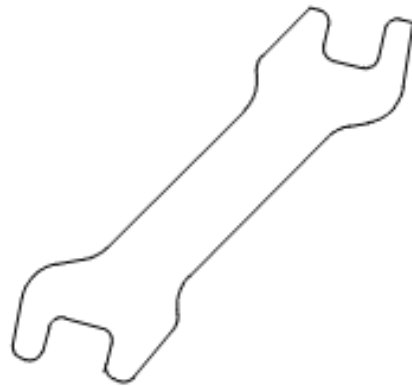

**#113.** 13/15mm Wrench

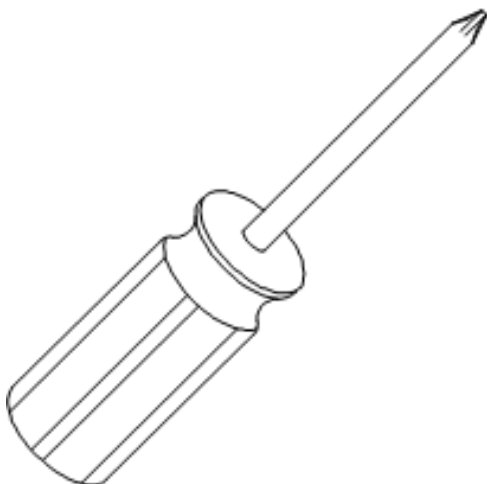

**#114.** Phillips Head Screwdriver

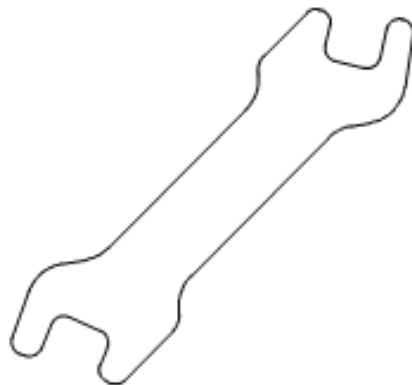

**#130.** 13/14mm Wrench

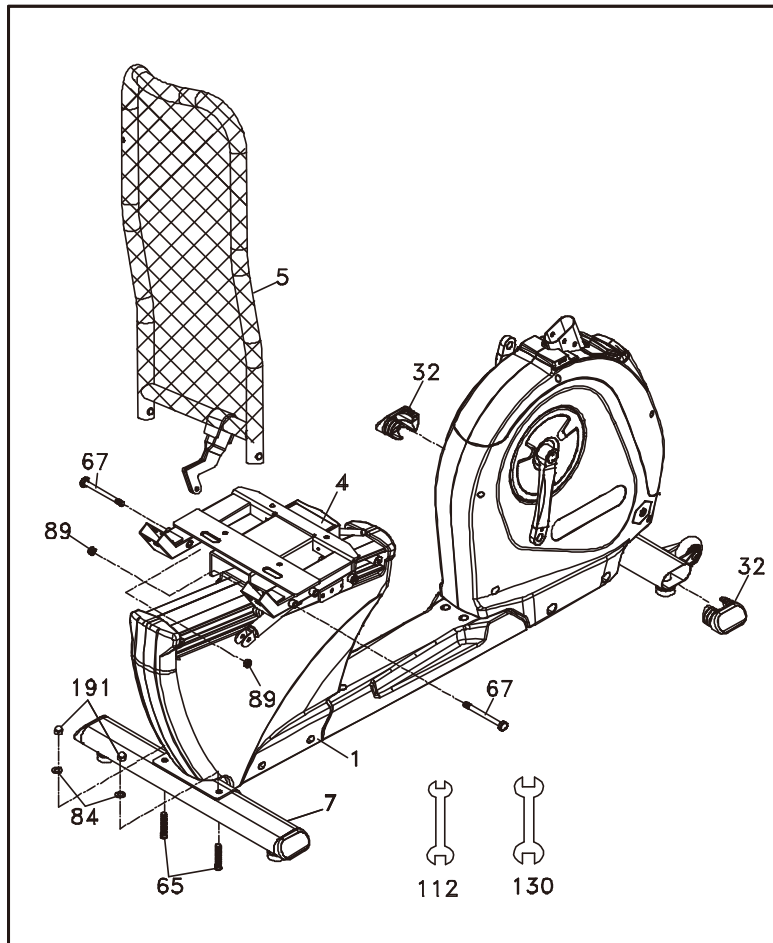

## STEP 1:

1. Attach the **REAR STABILIZER (7)** to the **MAIN FRAME (1)** with **2 BOLTS (65)** and **2 FLAT WASHERS (84)** and **2 CAP NUTS (191)**. Tighten completely with the **WRENCH (112)**.
2. Attach the **SEAT BACK (5)** to the **SEAT CARRIAGE (4)** of the main frame. Slide **1 BOLT (67)** through each side, then attach a **NYLON NUT (89)** to each bolt. Tighten the bolts just enough so there is no side-to-side play, but freedom of movement front to back. Use the **WRENCHES** provided (**112 & 130**).
3. Insert an **END CAP (32)** into each opening of the **Front Stabilizer Tube**. You may need to tap them in with a rubber mallet if they are resistant to being put in.

## HARDWARE

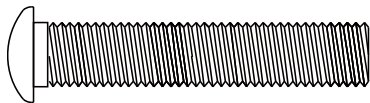

**#65.** 3/8" × 53mm  
Carriage Bolt (2 pcs)

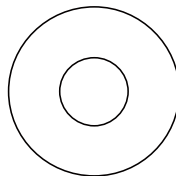

**#84.** 3/8" × 25 × 2T  
Flat Washer (2 pcs)



**#89.** 3/8" × 7T  
Nylon Nut (2 pcs)



**#191.** 3/8"  
Cap Nut (2 pcs)

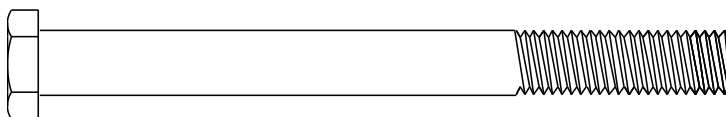

**#67.** 3/8" × 4"  
Hex Head Bolt (2 pcs)



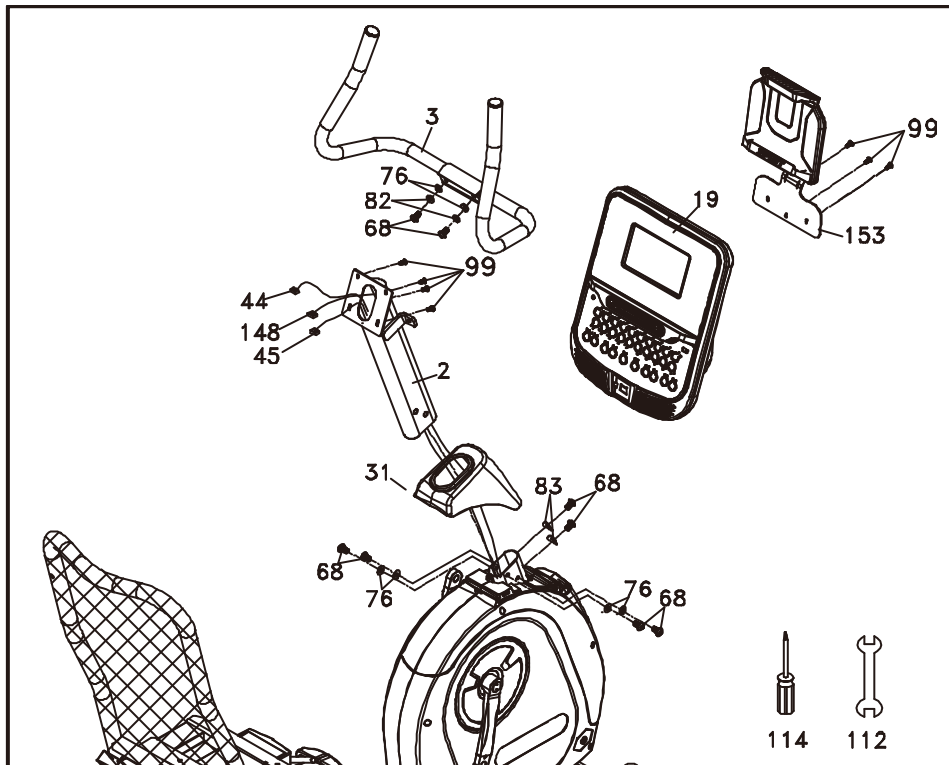

## STEP 2:

1. Slide the **COMPUTER CABLE (44)**, **HANDLEBAR RESISTANCE CONTROL CABLE (148)**, and **HAND PULSE CABLE (45)** through the bottom of the **CONSOLE MAST COVER (31)** and then the bottom of the **CONSOLE MAST (2)**. Make sure the Console Mast Cover is correctly oriented (see illustration).
2. Install the **CONSOLE MAST (2)** into the receiving tube (make sure not to pinch cables; damage to the electronics could occur) of the **MAIN FRAME (1)**. Insert **2 BOLTS (68)** and **2 FLAT WASHERS (76)** on each side. Insert **2 BOLTS (68)** and **2 CURVED WASHERS (83)** on the front. Tighten all 6 bolts firmly with the **WRENCH (112)**. Remove the white Styrofoam pad (factory installed to prevent bolts from being accidentally dropped into the Console Mast Tube).
3. Insert the **COMPUTER CABLE (44)**, **HANDLEBAR RESISTANCE CONTROL CABLE (148)**, and **HAND PULSE CABLE (45)** into their respective connectors in the back of the **CONSOLE ASSEMBLY (19)**. Attach the console onto the mounting plate with **4 PHILLIPS HEAD SCREWS (99)**. Tighten with the **PHILLIPS HEAD SCREWDRIVER (114)**.
4. Attach the **CONSOLE HOLDER (153)** to the **CONSOLE ASSEMBLY (19)** with **3 PHILLIPS HEAD SCREWS (99)**. Tighten with the **PHILLIPS HEAD SCREWDRIVER (114)**.
5. Attach the **HANDLE BAR ASSEMBLY (3)** onto the **CONSOLE MAST (2)** bracket with **2 BOLTS (68)**, **2 SPLIT WASHERS (82)**, and **2 FLAT WASHERS (76)**. Completely tighten with the **WRENCH (112)**.

## HARDWARE

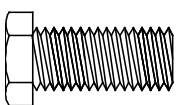

**#68.** 5/16" × 5/8"  
Hex Head Bolt (8 pcs)

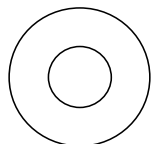

**#76.** 5/16" × 18 × 1.5T  
Flat Washer (6 pcs)



**#82.** 5/16" × 1.5T  
Split Washer (2 pcs)

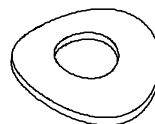

**#83.** 5/16" × 19 × 1.5T  
Curved Washer (2 pcs)

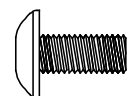

**#99.** M5 × 12mm Phillips  
Head Screw (7 pcs)

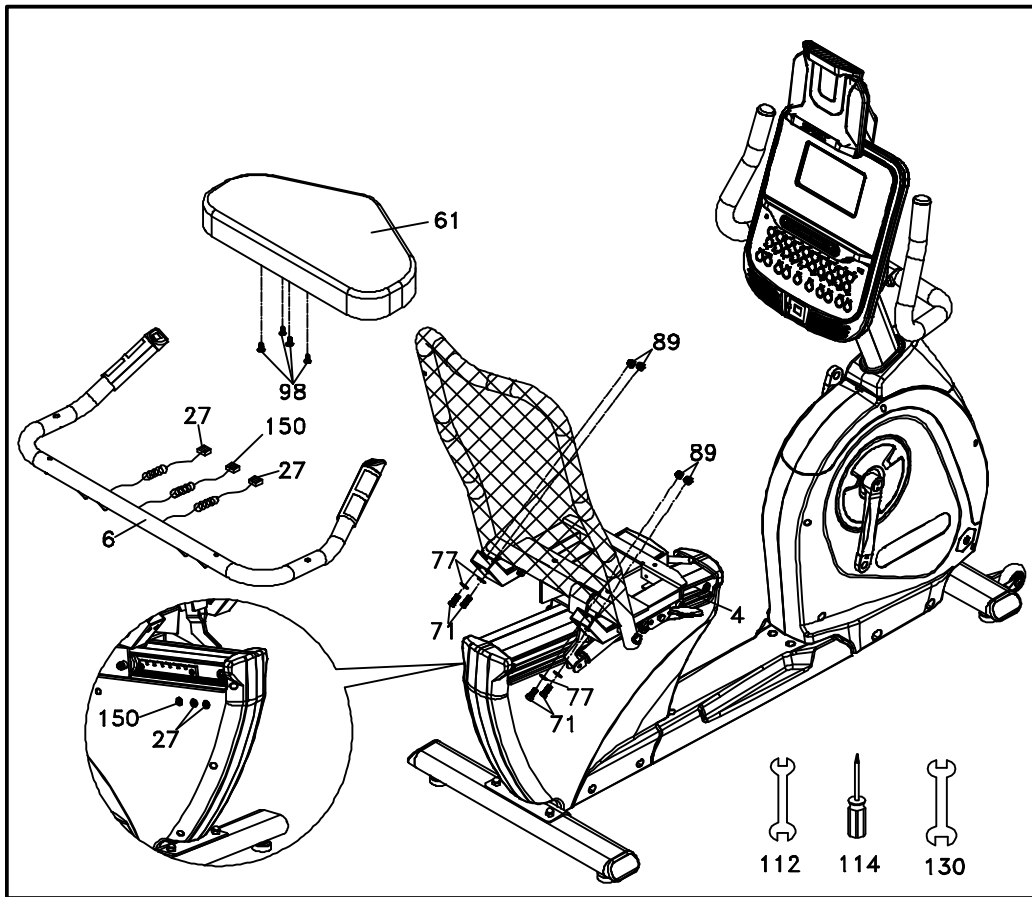

### STEP 3:

1. Install the **SEAT (61)** on the **SEAT CARRIAGE (4)** with **4 PHILLIPS HEAD SCREWS (98)**. Tighten with the **PHILLIPS HEAD SCREWDRIVER (114)**.
2. Attach the **SEAT HANDLEBAR (6)** to the **SEAT CARRIAGE (4)** with the **4 Hex Head Bolts (71)**, **4 FLAT WASHERS (77)**, and **4 NYLON NUTS (89)**. Tighten with the **WRENCHES provided (112 & 130)**.
3. Plug the **HAND PULSE SENSOR CABLES (27)** into the rear two holes on the left side of the rear plastic cover. Plug the **HANDLEBAR RESISTANCE CABLES (150)** into the remaining front hole.

### HARDWARE

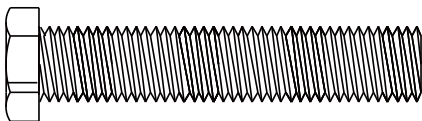

**#71.** 3/8" × 1-3/4"  
Hex Head Bolt (4 pcs)

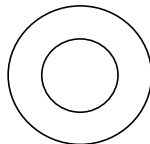

**#77.** 3/8" × 19 × 1.5T  
Flat Washer (4 pcs)

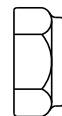

**#89.** 3/8" × 7T  
Nylon Nut (4 pcs)

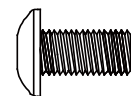

**#98.** M6 × 15mm  
Phillips Head Screw (4 pcs)

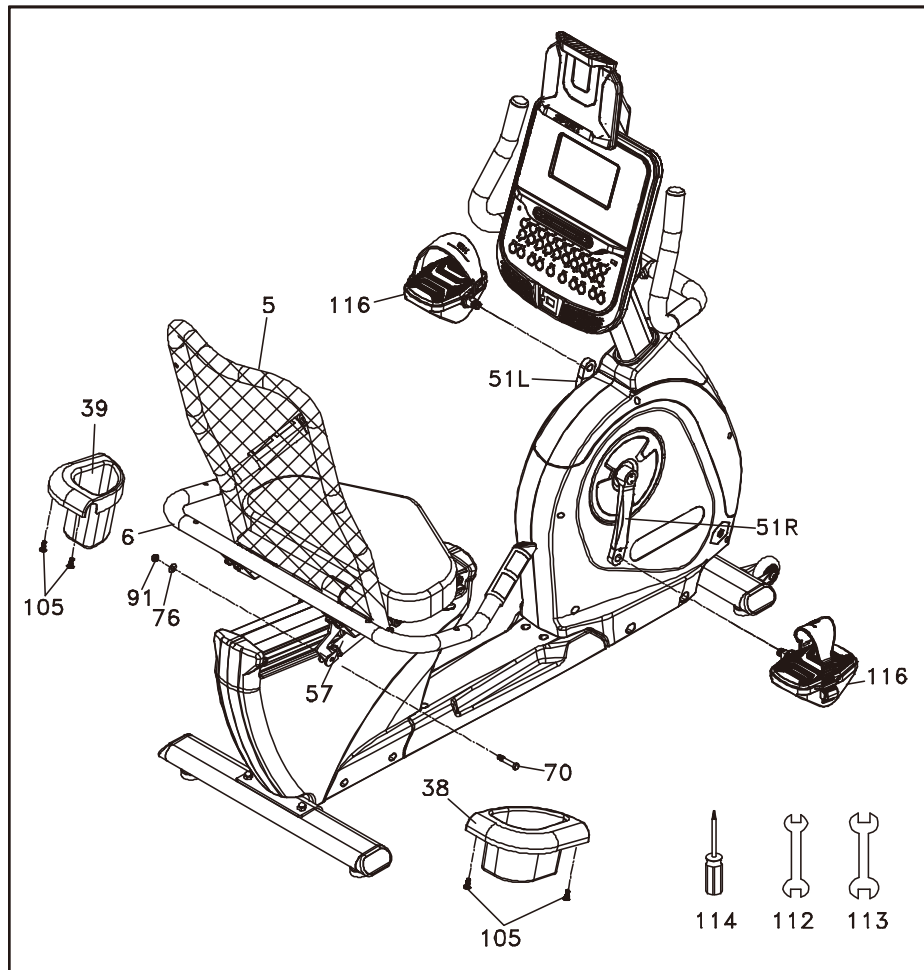

## STEP 4:

1. Install the **GAS CYLINDER (57)** on the **SEAT BACK FRAME (5)** with 1 **BOLT (70)**, 1 **FLAT WASHER (76)** and 1 **NYLON NUT (91)** by using the **WRENCHES** provided (112 & 113).
2. Attach the **PEDALS (116)** to the **CRANK ARMS (51L, 51R)**. Tighten with the **WRENCH (113)**. Remember that the **LEFT PEDAL** has a reverse thread and will be threaded onto the Crank arm in a **COUNTERCLOCKWISE** motion. There is an "L" stamped at the end of the threaded post of the left pedal and an "R" on the right. Make sure to tighten the pedals as firmly as you can. It may be necessary to re-tighten the pedals if you feel a thumping while pedalling the bike. A thumping or clicking noise is usually caused by loose pedals.
3. Attach the **DRINK BOTTLE HOLDERS (39L & 38R)** to the sides of the **SEAT HANDLEBAR (6)** with 4 **SHEET METAL SCREWS (105)**. Tighten with the **PHILLIPS HEAD SCREWDRIVER (114)**.

## HARDWARE

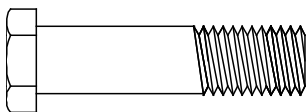

**#70.** 5/16" × 1-1/4"  
Hex Head Bolt (1 pc)

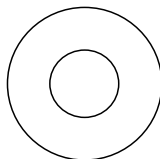

**#76.** 5/16" × 18 × 1.5T  
Flat Washer (1 pc)

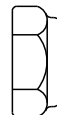

**#91.** 5/16" × 6T  
Nylon Nut (1 pc)

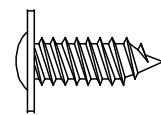

**#105.** 4 × 16mm  
Sheet Metal Screw (4 pcs)

# Setting Up Your Bike

Use a M14 Wrench to adjust the height of the Leveling Feet.



## ■ Moving The Recumbent Bike

The Bike is equipped with 2 transport wheels on the front stabilizer. Lift the bike by the rear stabilizer and gently tilt the bike up and roll it away.



# ABOUT YOUR UPRIGHT BIKE

Always use care and caution when operating your upright bike. Follow the instructions in this manual to ensure the safe operation and maintenance of your upright bike.

Your new Spirit Fitness upright bike has Bluetooth connectivity to give you access to the most advanced workout experiences available. Follow the instructions below to learn more about using the Bluetooth capabilities to their fullest potential.



Downloading the Spirit+ app will help unlock more features- such as tracking workouts and sharing data via Google Fit and Apple Fitness. Simply search for “Spirit+” in the app store on your smartphone or tablet or scan the QR code below.

Did you know that you can personalize your experience with your new upright bike? Create a profile and save custom work- out programs by following the instructions below.

## USING THE SPIRIT+ APP

In order to help you achieve your exercise goals, your new upright bike comes equipped with a Bluetooth® transceiver that will allow it to interact with selected phones or tablet computers via the Spirit+ App. Just download the free Spirit+ App from the Apple Store or Google Play, and then follow the instructions in the App to sync with your upright bike.

Press the “DISPLAY” button from the APP to view the display of the current workout data. When your exercise is complete, choose “END & SAVE WORKOUT” to store the workout data. The Spirit + App also allows you to sync your workout data with one of many fitness cloud sites we support Apple Health, Google Fit, MapMyFitness or Fitbit, with more to come.

1. Download the App by scanning the QR code on the right.
2. Open the App on your device (phone or tablet) and make sure Bluetooth® is enabled on your device (phone or tablet).
3. In the App click the Bluetooth® icon to search for your Spirit + equipment.
4. Under the Bluetooth® scan result list, select the upright bike for connection. When the App and equipment are synced, the Bluetooth® icon on the equipment’s console display will light up. Click “DISPLAY”, you may now start using your Spirit + App.
5. When your exercise is complete, choose “END & SAVE WORKOUT” to store the workout data. You will be prompted to sync your data with each available fitness cloud site. Please note, you will have to download the applicable compatible fitness App, such as Apple Health, Google Fit, MapMyFitness, Fitbit, etc., for the icon to be active and available.



Note: Your device will need to be running on a minimum operating system of IOS 13.1 or Android 8.0 for the Spirit + App to operate properly.

The exercise equipment can also play music wirelessly via Bluetooth®. Turn on your mobile phone or tablet’s Bluetooth® function. Search for the name “Bt-speaker” in your device’s Bluetooth® menu. Tap to connect. Now your device can transmit music to the exercise equipment.

The icon  lights up and the heart rate is displayed when successfully connected to a Bluetooth® heart rate chest strap. The icon will be off when the Bluetooth® heart rate chest strap is disconnected.

# OPERATION OF YOUR CONSOLE



## Powering On

The XBR95 Recumbent Bike has a built-in generator for power and does not need to be plugged into an AC outlet. To power up the bike simply start to pedal, and the console will turn on automatically.

When initially powered on the console will perform an internal self-test. During this time all the lights will turn on. When the lights go off, the Message Center will show the software version (i.e.: VER 1.0). The distance window shows the distance in km (miles) and the time window shows the total hours of use.

The odometer will remain displayed for only a few seconds then the console will go to the start-up display. The dot matrix display will be scrolling through the different profiles of the programs and the Message Center will be scrolling the start-up message. You may now begin to use the console.

## Quick Start

After the console powers up you just press the **Start** key to begin, this will initiate the Quick Start mode. In Quick Start the Time will count up from zero and the workload may be adjusted manually by pressing the **Level + / - buttons**. The dot matrix display will have only the bottom row lit at first. As you increase the workload more rows will light indicating a harder workout. The fitness bike will get harder to pedal as the rows increase.

There are 40 levels of resistance available for plenty of variety. The first 10 levels are very easy workloads and the changes between levels are set to a good progression for de-conditioned users. Levels 11-20 are more challenging, but the increases in resistance from one level to the next remain small. Levels 21-30 start getting tougher as the levels jump more dramatically. Levels 31-40 are extremely hard and are good for short-interval peaks and elite athletic training.

## FEATURES

### Basic Information

The **Stop** button has several functions. Pressing the **Stop** key once during a program will pause the program for 5 minutes. If you need to get a drink, answer the phone or do any of the many things that could interrupt your workout, this is a great feature.

To resume your workout during Pause, just press the **Start** key. If the **Stop** button is pressed twice during a workout, the program will end and the console will display your Workout Summary (Total time, Avg. Speed, Avg. Watts, Avg. HR). If the **Stop** key is held down for 3 seconds or a third time during the program, the console will perform a complete Reset. During data entry for a program, the **Stop** key performs a previous screen or segment function. This allows you to go back to change programming data.

### Program Key

The Program Key is used to preview each program. When you first turn the console on you may press the program key to preview what the program profile looks like.

The Recumbent bike has a built-in heart rate monitoring system. Simply grasping the hand pulse sensors on the stationary handlebars or wearing the heart rate transmitter (see Using Heart Rate Transmitter section) will start the Heart Icon blinking (this may take a few seconds). The Pulse Display Window will display your heart rate or Pulse in beats per minute.

### Console

The console will display RPM, Calories burned, Time (elapsed or countdown), Distance travelled, Pulse, Resistance, Program Name, number of Laps completed, and Segment Time. There is also a Resistance profile graph that lets you see how hard you have worked and how challenging the upcoming segments will be.

## Dot Matrix Center Display

Twenty columns (10 high) indicate each segment of a workout. The boxes only show an approximate level (resistance) of effort. They do not necessarily indicate a specific value - only an approximate percent to compare levels of intensity. In Manual Operation the resistance dot matrix window will build a profile “picture” as values are changed during a workout.

## Built-in Fan

The console includes a built-in fan to help keep you cool. To turn the fan on, press the button on the left side of the console.

## Charge Portable Devices with USB port

Charge your device during your workout using the fitness equipment’s on-console USB port. To charge your mobile electronics make sure the fitness equipment power is on.

Step 1: Connect your USB charging cable (not included) to the USB Power Port and your device.

Step 2: Check to make sure your device icon indicates it is charging.

### **NOTE:**

- USB charging cable is not included, make sure compatible USB charging cable is being used.
- The USB port on the console is capable of powering USB devices. It provides up to 5Vdc/1.0 amp of power and meets USB 2.0 regulations. You will not be able to save your workout data to a USB via this port; it is used for charging purposes only.
- The minimum speed must reach 40 RPM or above to generate enough power for USB charging.



## Calorie Display

Displays the cumulative calories burned at any given time during your workout.

**Note:** This is only a rough guide used for comparison of different exercise sessions and is not to be used for medical purposes.

## Direct Resistance Buttons

You can set your resistance level setting quickly by pressing the buttons on the console. Simply choose the desired level of resistance from the console and the Recumbent Bike will automatically adjust to that level. This saves time because you don’t have to press and hold or hold a button down until reaching the desired value.

## Pulse Grip Feature

The Pulse (Heart Rate) console window will display your current heart rate in beats per minute during the workout. You must use both stainless-steel sensors on the front cross bar or the heart rate transmitter chest strap to display your pulse. Pulse value displays anytime the upper display is receiving a Pulse signal. You may not use the Grip Pulse feature while in Heart Rate Programs.



# PROGRAMMABLE FEATURES

## Programming the Console

Each of the programs can be customized with your personal information and changed to suit your needs. Some of the information asked for is necessary to ensure the readouts are correct. You will be asked for your Age and Weight. Entering your Age is necessary during the Heart Rate programs to ensure the correct settings are in the program for your Age. Your weight is used to give a more accurate calorie count.

**CALORIE NOTE:** Calorie readings on every piece of exercise equipment, whether it is in a gym or at home, are not accurate and tend to vary widely. They are meant only as a guide to monitor your progress from workout to workout. The only way to measure your calorie burn accurately is in a clinical setting connected to a host of machines. This is because every person is different and burns calories at a different rate. Some good news is that you will continue to burn calories at an accelerated rate for at least an hour after you have finished exercising!

## Entering a Program and Changing Settings

When you enter a program, by pressing the **Program** key, then **Enter** key, you have the option of entering your settings. If you want to work out without entering new settings, then just press the **Start** key. This will bypass the programming of data and take you directly to the start of your workout. If you want to change the personal settings, then just follow the instructions in the Message Center. If you start a program without changing the settings, the default or saved settings will be used.

**NOTE:** Age and Weight default settings will change when you enter a new number. So, the last Age and Weight entered will be saved as the new default settings. If you enter your Age and Weight the first time you use the fitness bike, you will not have to enter it every time you work out unless either your Age or Weight changes or someone else enters a different Age and Weight.

# PROGRAMS - TO SELECT AND START A PROGRAM

## Preset

1. Press the **PROGRAM** key to select the desired program button, then press the **Enter** key.
2. The Message Center will ask you to enter your Age.  
You may adjust the age setting, using the **+ and -** keys, then press the **Enter** key to accept the new number and proceed on to the next screen.
3. You are now asked to enter your Weight. You may adjust the weight number using the **+ and -** keys, then press **Enter** to continue.
4. Next is Time. You may adjust the Time and press **Enter** to continue.
5. Now you are asked to adjust the Max Resistance Level.  
This is the peak exertion level you will experience during the program (at the top of the hill). Adjust the level and then press **Enter**.
6. Now you are finished editing the settings and can begin your workout by pressing the **Start** key.
7. If you want to increase or decrease the workload at any time during the program press the **+ or -** key.
8. During the program you will be able to scroll through the data in the Message Center by pressing the **Enter** key.
9. When the program ends the Message Center will show a summary of your workout. The summary will be displayed for a short time then the console will return to the start-up display.

## Manual

The Manual program works as the name implies, manually. This means that you control the workload and not the computer. To start the Manual program, follow the instructions below.

1. Press the **PROGRAM** key to select Manual, then press the **Enter** key.
2. The Message Center will ask you to enter your Age. You may enter your age, using the **Level +/- keys**, then press the **Enter** key to accept the new value and proceed on to the next screen.
3. You are now asked to enter your Weight. You may adjust the Weight value using the **Level +/- keys**, then press **Enter** to continue.
4. Next is Time. You may adjust the Time and press **Enter** to continue.
5. Now you have finished editing the settings and can begin your workout by pressing the **Start** key. You can also go back and modify your settings by pressing the **Enter** key.
6. Once the program starts you will be at level one. This is the easiest level, and it is a good idea to stay at level one for a while to warm up. If you want to increase the workload at any time press the **Level + key**; the **Level - key** will decrease the workload.
7. During the Manual program you will be able to scroll through the data in the Message Center by pressing the **Enter** key.
8. When the program ends, you may press **Start** to begin the same program again or **Stop** to exit the program.

# PROGRAMS - PRESET

The Recumbent Bike has multiple different programs that have been designed for a variety of workouts. These six programs have factory preset work level profiles for achieving different goals.

## Hill

This program follows a triangle or pyramid type of gradual progression from approximately 10% of maximum effort (the level that you chose before starting this program) up to a maximum effort which lasts for 10% of the total workout time, then a gradual regression of resistance back to approximately 10% of maximum effort

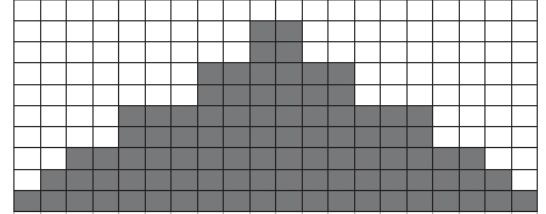

## Fat Burn

This program follows a quick progression up to the maximum resistance level (default or user input level) that is sustained for 2/3 of the workout. This program will challenge your ability to sustain your energy output for an extended period.

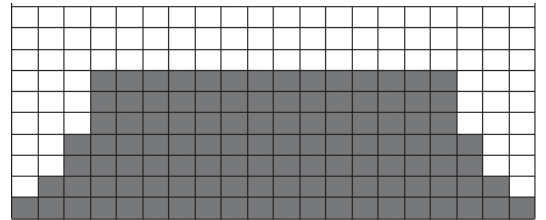

## Cardio

This program presents a quick progression up to near maximum resistance level (default or user input level). It has slight fluctuations up and down to allow your heart rate to elevate, and then recover repeatedly, before beginning a quick cool down. This will build up your heart muscle and increase blood flow and lung capacity.

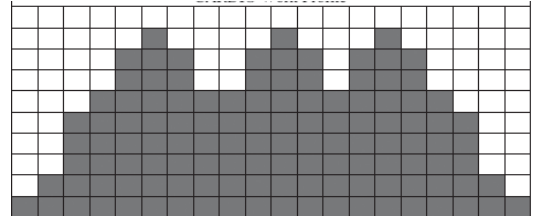

## Strength

This program has a gradual progression of resistance up to 100% of maximum effort that is sustained for 25% of the workout duration. This will help build strength and muscular endurance in the lower body and glutes. A brief cool-down follows.

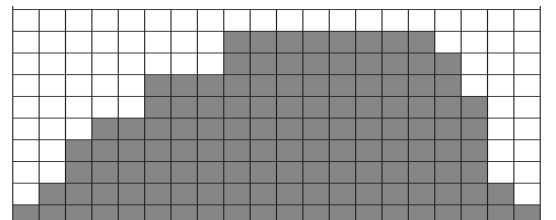

## HIIT

This program takes you through high levels of intensity followed by recovery periods of low intensity. This program utilizes and develops your “Fast Twitch” muscle fibres which are used when performing tasks that are intense and short in duration. These deplete your oxygen level and spike your heart rate, followed by periods of recovery and heart rate drop to replenish oxygen. Your cardiovascular system gets programmed to use oxygen more efficiently.

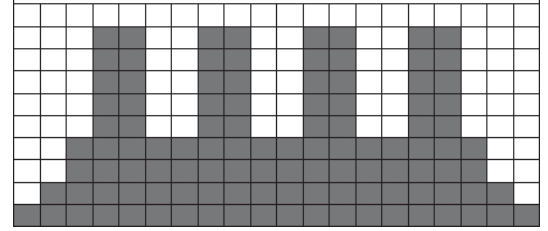

## Fusion

This program takes you through high levels of cardio & strength intensity followed by recovery periods of low intensity. This program utilizes and develops your “Fast Twitch” muscle fibres which are used when performing tasks that are intense and short in duration. These deplete your oxygen level and spike your heart rate, followed by periods of recovery and heart rate drop to replenish oxygen. Your cardiovascular system gets programmed to use oxygen more efficiently.

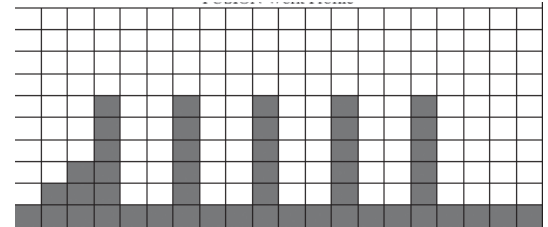

# PROGRAMS

## Fusion

In this interval program, you will alternate between mid-high-intensity cardiovascular intervals on the bike, strength exercises off of the bike, and low-intensity recovery intervals on the bike. You will need a pair of objects that can be comfortably held in your hands (dumbbells, water jugs, soup cans, etc.) for 4 of the 5 strength exercises performed in this program.

1. Press **the PROGRAM** key to select the Fusion program button, then press the **Enter** key.
2. If **Enter** was pressed, the Message center will now be blinking a value, indicating your Age (default is 35). Use the **Level +/- keys** to adjust, then press **Enter**. Your age determines your recommended maximum heart rate. Since the Bar Graph Display and the Heart Rate features are based on a percentage of your maximum heart rate, it is important to enter the correct age for these features to work properly.
3. The Message Center will now be blinking a value, indicating your Body Weight. Entering the correct body weight will affect the calorie count. Use the **Level +/- keys** to adjust, then press **Enter**.

**Note about the Calorie display:** No exercise machine can give you an exact calorie count because there are too many factors which determine the exact calorie burn for a particular person. Even if someone is the same body weight, age and height, their calorie burn may be very different from yours. The Calorie display is to be used as a reference only to monitor improvement from workout to workout. The calorie count displayed in this program won't be accurate because the machine can't calculate calories expended while strength training.

4. The Message Center will now be blinking the preset top Resistance level of the selected program (default/minimum resistance is Level 5). Use the **Level +/- keys** to adjust, then press **Enter**. This value will be the Level for all cardio intervals. The resistance level can be adjusted at any time during the program.
5. The Message Center will be blinking the number of intervals desired (default is 10); you may select 10 (5 cardio & 5 strength), 20 (10 cardio & 10 strength), or 30 (15 cardio & 15 strength). Use the **Level +/- keys** to adjust, then press **Enter**.
6. The Message Center will be blinking the desired Interval time (default is 2:00). The time you select will be the duration of each cardio interval. Note: As a general rule, the longer the interval, the less resistance (fitness bike) is required and the more repetitions you perform, the less weight (dumbbells) you need to use; use the **Level +/- keys** to adjust, then press **Enter**.
7. The Message Center will be blinking the recovery time you desire (default is 0:30) after completing both the cardio & strength intervals. Use the **Level +/- keys** to adjust, then press **Enter**.

**CAUTION:** The shorter the recovery time, the longer your heart rate will stay elevated; if you are new to exercise or have recently resumed an exercise program after a considerable amount of time off, it is recommended that your recovery interval length either matches or exceeds the length of the cardio interval.

## Countdown Mode

Target programs can set a Target Time, Target Distance or Target Calories for your workout. When the program begins the target item will count down; once it reaches zero the program ends.

1. Press the **PROGRAM** key to select **TARGET PROGRAM**, then press **Enter**.
2. Press the **PROGRAM** key to select the Target Time program, Target Distance program or Target Calories program. Press **Enter** to set the program. The display will prompt you through the programming or you can just press **Start** to begin the program with default values.
3. If **Enter** was pressed, the Message center will now be blinking a value, indicating your **Age** (default is 35). Use the **+ or -** keys to adjust, then press **Enter**.
4. The Message center will now be blinking a value, indicating your **Body Weight** (default is 155 lbs/ 70kgs.). Entering the correct body weight will affect the calorie count. Use the **+ or -** keys to adjust, then press **Enter**.  
A note about the Calorie display: No exercise machine can give you an exact calorie count because there are too many factors which determine the exact calorie burn for a particular person. Even if someone is the same body weight, age and height, their calorie burn may be very different than yours. The Calorie display is to be used as a reference only to monitor improvement from workout to workout.
5. In the Target Time program, the Message Center will be blinking a value, indicating **Time** (the default value is 5 minutes) In the Target Distance program, the Message Center will be blinking a value, indicating **Distance** (the default value is 3.00 mile) In Target Calories program, the Message Center will be blinking a value, indicating **Calories** (the default value is 300). You may use any of the **+ or -** keys to adjust the target item. After adjusting, or accepting the default, press **Enter**.
6. You are now done programming data and may press **Start** to begin your workout.

## Custom Workout Program

Two customizable User programs allow you to build and save your workout. The two programs, Custom 1 and Custom 2, operate the same way so there is no reason to describe them separately. You can build your custom program by following the instructions below or you can save any other preset program you complete as a custom program. Both programs allow you to further personalize it by adding your name.

1. Press the **PROGRAM** key to select the Custom program button (Custom 1 or Custom 2), then press the **Enter** key. If you have already saved a program to either Custom 1 or Custom 2, it will be displayed and you are ready to begin. If not, you will have the option of inputting a username. In the Message Window, the letter "A" will be blinking. Use the **Level +/-** buttons to select the appropriate first letter of your name (pressing the **LEVEL +/-** button will switch to the letter "B"; pressing the Down button will switch to the letter "Z"). Press **Enter** when the desired letter is displayed. Repeat this process until all of the characters of your name have been programmed (maximum 7 characters). When finished press **Stop**.
2. If there is a program already stored in Custom when you press the key, you will have an option to run the program as it is or delete the program and build a new one. At the welcome message screen, when pressing **Start or Enter** you will be prompted: Run Program? Use the **Level +/-** to select Yes or No. If you select No, you will then be asked if you want to delete the currently saved program. It is necessary to delete the current program if you want to build a new one. The Message Center will ask you to enter your Age. You may enter your age, using the **Level +/-** keys, then press the **Enter** key to accept the new value and proceed on to the next screen.

3. The Message Center will ask you to enter your Age. You may enter your age, using the **Level +/-** keys, then press the **Enter** key to accept the new value and proceed on to the next screen.
4. You are now asked to enter your Weight. You may adjust the weight value using the **Level +/-** keys, then press **Enter** to continue.
5. Next is Time. You may adjust the time and press **Enter** to continue.
6. Now the first column will be blinking and you are asked to adjust the resistance level for the first segment (SEGMENT> 1) of the workout by using the **Level +/-** key. When you finish adjusting the first segment, or if you don't want to change, then press **Enter** to continue to the next segment.
7. The next segment will show the same workload resistance level as the previously adjusted segment. Repeat the same process as the last segment then press **Enter**. Continue this process until all twenty segments have been set.
8. Now you are finished editing the settings and can begin your workout by pressing the **Start** key. You can also go back and modify your settings by pressing the **Enter** key.

## Heart Rate Program Operation

Note: You must wear the heart rate transmitter strap for these programs. Both programs operate the same.

Heart Rate programs operate the same, the only difference is that **HR1** is set to 55%, **HR2** is set to 65%, **HR3** is set to 75% and **HR4** is set to 85% of the maximum heart rate. They are programmed the same way. To start an HR program follow the instructions below or just select the **HR 55%**, **HR 65%**, **HR 75%** or **HR 85%** program, then the Enter button and follow the directions in the **Message Center**.

After selecting your heart rate target, the program will attempt to keep you at or within 3 - 5 heartbeats per minute of this value. Follow the prompts in the **Message Center** to maintain your selected heart rate value.

1. Press the **PROGRAM KEY** to select **HR PROGRAM** then press **ENTER**.
2. Press the **PROGRAM** key to select target HR 55%, target HR 65%, target HR 75% or target 85%, then press the **Enter** key.
3. The Message Center will ask you to enter your **Age**. You may enter your age, using the **Level + or -** keys, then press the **Enter** key to accept the new value and proceed on to the next screen.
4. You are now asked to enter your Weight. You may adjust the weight value using the **Level + or -** keys, then press **Enter** to continue.
5. Next is Time. You may adjust the time using the **Level + or -** keys and press **Enter** to continue.
6. Now you are asked to adjust the Heart Rate Target. This is the heart rate level you will strive to maintain during the program. Adjust the level using the **Level + or -** keys, then press **Enter**.  
**Note:** The heart rate that appears is based on the % you accepted in Step 2. If you change this number it will either increase or decrease the % from Step 2.
7. Now you are finished editing the settings and can begin your workout by pressing the **Start** key. You can also go back and modify your settings by pressing the **Enter** key.  
**Note:** At any time during the editing of Data you can press the **Stop** key to go back one screen.
8. If you want to increase or decrease the workload at any time during the program press the **Level + or -** key on the console. This will allow you to change your target heart rate at any time during the program.

# HEART RATE EXERTION

The old motto, “no pain, no gain”, is a myth that has been overpowered by the benefits of exercising comfortably. A great deal of this success has been promoted by the use of heart rate monitors. With the proper use of a heart rate monitor, many people find that their usual choice of exercise intensity was either too high or too low and exercise is much more enjoyable by maintaining their heart rate in the desired benefit range.

To determine the benefit range in which you wish to train, you must first determine your Maximum Heart Rate. This can be accomplished by using the following formula: 220 minus your age. This will give you the Maximum Heart Rate (MHR) for someone of your age. To determine the effective heart rate range for specific goals you simply calculate a percentage of your MHR. Your Heart rate training zone is 50% to 90% of your maximum heart rate. 60% of your MHR is the zone that burns fat while 80% is for strengthening the cardiovascular system. This 60% to 80% is the zone to stay in for maximum benefit.

For someone who is 40 years old, their target heart rate zone is calculated:

$220 - 40 = 180$  (maximum heart rate)  
 $180 \times .6 = 108$  beats per minute  
(60% of maximum)  
 $180 \times .8 = 144$  beats per minute  
(80% of maximum)

So, for a 40-year-old, the training zone would be 108 to 144 beats per minute.

If you enter your age during programming the console will perform this calculation automatically. Entering your age is used for the Heart Rate programs. After calculating your MHR you can decide upon which goal you would like to pursue.

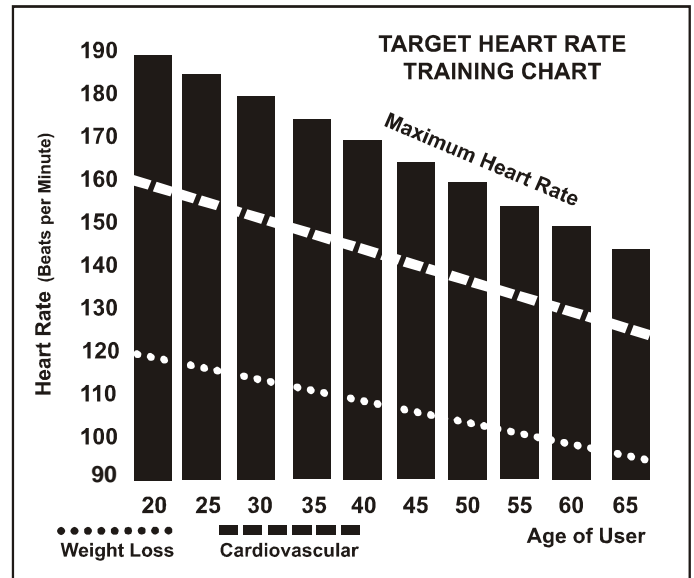

The two most popular reasons for, or goals, of exercise, are cardiovascular fitness (training for the heart and lungs) and weight control. The black columns on the chart above represent the MHR for a person whose age is listed at the bottom of each column. The training heart rate, for either cardiovascular fitness or weight loss, is represented by two different lines that cut diagonally through the chart. A definition of the lines' goal is in the bottom left-hand corner of the chart. If your goal is cardiovascular fitness or if it is weight loss, it can be achieved by training at 80% or 60% respectively, of your MHR on a schedule approved by your physician. Consult your physician before participating in any exercise program.

With all Heart Rate program upright bikes, you may use the heart rate monitor feature without using the Heart Rate program. This function can be used during manual mode or any of the nine different programs. The Heart Rate program automatically controls incline.



# HEART RATE - PERCEIVED EXERTION

Heart rate is important but listening to your body also has a lot of advantages. There are more variables involved in how hard you should work out than just heart rate. Your stress level, physical health, emotional health, temperature, humidity, the time of day, the last time you ate, and what you ate, all contribute to the intensity at which you should workout. If you listen to your body, it will tell you all of these things.

The rate of perceived exertion (RPE), also known as the Borg scale, was developed by Swedish physiologist G.A.V. Borg. This scale rates exercise intensity from 6 to 20 depending upon how you feel or the perception of your effort.

The scale is as follows:

## Rating Perception of Effort

- 6 Minimal
- 7 Very, very light
- 8 Very, very light +
- 9 Very light
- 10 Very light +
- 11 Fairly light
- 12 Comfortable
- 13 Somewhat hard
- 14 Somewhat hard +
- 15 Hard
- 16 Hard +
- 17 Very hard
- 18 Very hard +
- 19 Very, very hard
- 20 Maximal

You can get an approximate heart rate level for each rating by simply adding a zero to each rating. For example, a rating of 12 will result in an approximate heart rate of 120 beats per minute. Your RPE will vary depending on the factors discussed earlier. That is the major benefit of this type of training. If your body is strong and rested, you will feel strong, and your pace will feel easier. When your body is in this condition, you can train harder and the RPE will support this. If you are feeling tired and sluggish, it is because your body needs a break. In this condition, your pace will feel harder. Again, this will show up in your RPE and you will train at the proper level for that day.

# USING HEART RATE TRANSMITTER (OPTIONAL)

How to wear your wireless chest strap transmitter:

1. Attach the transmitter to the elastic strap using the locking parts.
2. Adjust the strap as tightly as possible as long as the strap is not too tight to remain comfortable.
3. Position the transmitter centered in the middle of your torso facing away from your chest (some people must position the transmitter slightly left of center). Attach the end of the elastic strap by inserting the round end and, using the locking parts, secure the transmitter and strap around your chest.
4. Position the transmitter directly below the pectoral muscles.
5. Sweat is the best conductor to measure very minute heartbeat electrical signals.



However, plain water can also be used to pre-wet the electrodes (2 ribbed oval areas on the reverse side of the belt and both sides of the transmitter). It's also recommended that you wear the transmitter strap a few minutes before your workout. Some users, because of body chemistry, have a more difficult time achieving a strong, steady signal at the beginning. After "warming up", this problem lessens. As noted, wearing clothing over the transmitter/strap doesn't affect performance.

6. Your workout must be within range - distance between transmitter/receiver – to achieve a strong steady signal. The length of the range may vary somewhat but generally stay close enough to the console to maintain good, strong, reliable readings. Wearing the transmitter directly on bare skin assures you of proper operation. If you wish, you may wear the transmitter over a shirt. To do so, wet the areas of the shirt that the electrodes will rest upon.

*Note: The transmitter is automatically activated when it detects activity from the user's heart. Additionally, it automatically deactivates when it does not receive any activity. Although the transmitter is water resistant, moisture can have the effect of creating false signals, so you should take precautions to completely dry the transmitter after use to prolong battery life (estimated transmitter battery life is 2500 hours). The replacement battery is Panasonic CR2032.*

## Erratic Operation

Caution! Do not use this Upright Bike for Heart Rate program unless a steady, solid Actual Heart Rate value is being displayed. High, wild, random numbers being displayed indicate a problem.

Areas to look for interference that may cause erratic heart rate:

1. Microwave ovens, TVs small equipment etc.
  2. Fluorescent lights.
  3. Some household security systems.
  4. Perimeter fence for a pet.
  5. Some people have problems with the transmitter picking up a signal from their skin. If you have problems, try wearing the transmitter upside down.
  6. The antenna that picks up your heart rate is very sensitive. If there is an outside noise source, turning the whole machine 90 degrees may de-tune the interference.
  7. Another Individual wearing a transmitter within 3' of your machine's console.
- If you continue to experience problems, contact your dealer.

# MAINTENANCE & CARE

## POST-WORKOUT MACHINE CARE

1. Store your machine according to the folding instructions when not in use.
2. Use a slightly damp cloth to clean areas where sweat or oil made contact with the machine.
3. Use a microfiber cloth to clean the touchscreen and remove unwanted oils and other things that may damage the screen.
4. Avoid leaving paper or other small debris in the cupholders.

## SANITIZING YOUR FITNESS EQUIPMENT

- Upholstered high-contact surfaces (hard plastics) can be sanitized using a 75% isopropyl alcohol solution and a clean, dry cloth. Spray surfaces to be sanitized and use a dry cloth to wipe clean. Allow surfaces to dry before using.
- For upholstered or soft-plastic surfaces, use a conditioner after sanitizing. Be sure to follow the instructions provided by the conditioner manufacturer to ensure proper use of the conditioner.
- Alternatively, you can make your spray by mixing the proper ratio of isopropyl alcohol and distilled water to reach a 75% solution.

## Engineering Mode Menu

The console has built-in maintenance/diagnostic software. The software will allow you to change the console settings from English to Metric and turn off the beeping of the speaker when a key is pressed for example. To enter the Engineering Mode Menu, press and hold down the **Start**, **Stop** and **Enter** keys. Keep holding the keys down for about 5 seconds and the Message Center will display Engineering Mode Menu. Press the **Enter** key to access the menu below:

1. Key Test (Will allow you to test all the keys to make sure they are functioning)
2. Display Test (Tests all the display functions))
3. Functions (Press Enter to access settings and the+ or- arrow to scroll)
  - I. ODO Reset (Resets the odometer)
  - II. Units (Sets the display to readout in English or Metric display measurements)
  - III. Pause Mode (Turn on and allow 5 minutes of pause, and turn off to have the console pause indefinitely)
  - IV. Beep (Turns off the speaker so no beeping sound is heard)
  - V. PWM test (Test the Brake resistance)
4. Exit

# TROUBLESHOOTING

Problem	Solution/Cause
Squeak, thump, and clicking sound heard	<ol style="list-style-type: none"> <li>1. The hardware was not sufficiently tightened during assembly. All bolts that were installed during assembly need to be tightened as much as possible. It may be necessary to use a larger wrench than the one provided if you cannot tighten the bolts sufficiently. 90% of calls to the service department for noise issues can be traced to loose hardware.</li> <li>2. The crank arm nut needs to be retightened.</li> <li>3. If squeaks or other noises persist, check that the unit is properly levelled. There are 2 levelling pads on the bottom of the rear stabilizer, use a 14mm wrench (or adjustable wrench) to adjust the levellers</li> </ol>
Rough feeling when using the bike	<ol style="list-style-type: none"> <li>1. The hardware was not sufficiently tightened during assembly. All bolts that were installed during assembly need to be tightened as much as possible. It may be necessary to use a larger wrench than the one provided if you cannot tighten the bolts sufficiently. 90% of calls to the service department for noise issues can be traced to loose hardware.</li> <li>2. The crank arm nut needs to be retightened.</li> <li>3. If squeaks or other noises persist, check that the unit is properly levelled. There are 2 levelling pads on the bottom of the rear stabilizer, use a 14mm wrench (or adjustable wrench) to adjust the levellers</li> </ol>

# EXPLODED VIEW DIAGRAM

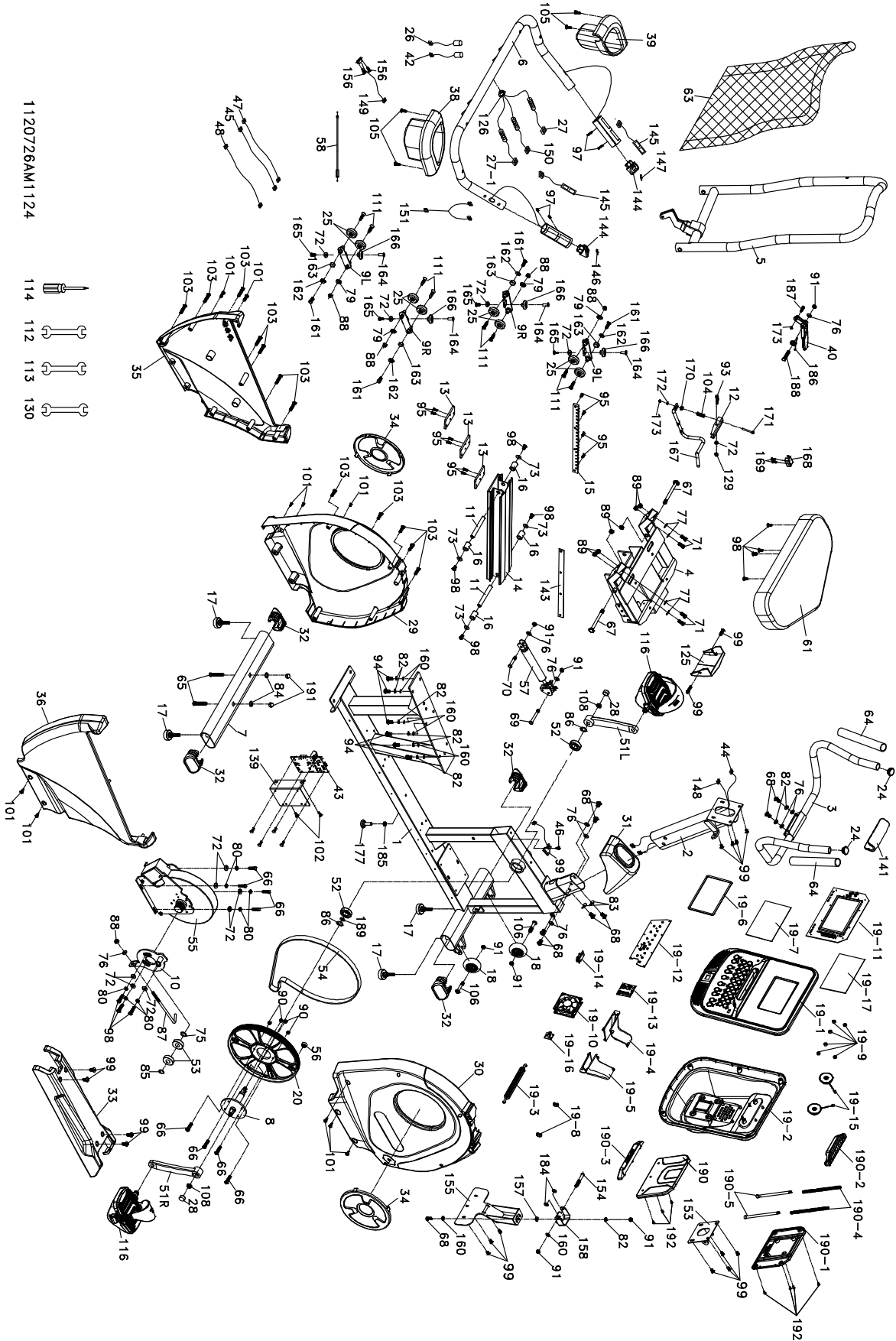

1120726AM1124

# PARTS LIST

Key	Part Description	Q'ty
1	Main Frame	1
2	Console Mast	1
3	Mast Handlebar Assembly	1
4	Seat Carriage	1
5	Seat Back Frame	1
6	Seat Handle Bar	1
7	Rear Stabilizer	1
8	Crank Axle	1
9L	Seat Wheel Adjustment Plate (L)	2
9R	Seat Wheel Adjustment Plate (R)	2
10	Idler Wheel Assembly	1
11	Seat Stop Axle	2
12	Seat Position Latch	1
13	Backing Plate	3
14	Aluminum Track	1
15	Rack	1
16	Spacer for Stopper Axle	4
17	Rubber Foot	4
18	Transportation Wheel	2
19	Console Assembly	1
19-1	Console Top Cover	1
19-2	Console Bottom Cover	1
19-3	Deflector Fan Grill	1
19-4	Wind Duct (L)	1
19-5	Wind Duct (R)	1
19-6	Water-resist Rubber	1
19-7	LCD Transparent Piece	1
19-8	Fan Grill Anchor	2
19-9	Speaker Grill Anchor	6
19-10	Fan Assembly	1
19-11	Console Display Board	1
19-12	Main Key Board	1
19-13	Interface Board	1
19-14	W/Receiver, HR	1
19-15	Speaker W/Cable	2
19-16	USB Board	1
19-17	Backlit Board	1
20	Drive Pulley	1
24	Button Head Plug	2
25	Seat Track Wheel	8
26	300mm_Hand Pulse Sensor Assembly W/Cable	1
27	750mm_Handpulse W/Cable Assembly(L)	1
27-1	950mm_Handpulse W/Cable Assembly(R)	1
28	Crank Arm End Cap	2
29	Front Shroud (L)	1

<b>Key</b>	<b>Part Description</b>	<b>Q'ty</b>
30	Front Shroud (R)	1
31	Console Mast Cover	1
32	Handgrip End Cap	4
33	Bottom Cover	1
34	Round Disk Cover	2
35	Rear Shroud (L)	1
36	Rear Shroud (R)	1
38	Drink Bottle Holder (R)	1
39	Drink Bottle Holder (L)	1
40	Release Lever	1
42	300mm_Hand Pulse Sensor Assembly W/Cable	1
43	Generator/Brake Controller	1
44	Computer Cable	1
45	2300mm_Hand Pulse Sensor Assembly W/Cable	1
46	1300mm_Sensor W/Cable	1
47	800mm_Wire Brake Coil Harness	1
48	Generator Wire Harness	1
51L	Crank Arm(L)	1
51R	Crank Arm(R)	1
52	6004_Bearing	2
53	6203_Bearing	2
54	Drive Belt	1
55	Flywheel	1
56	Magnet	1
57	Gas Cylinder	1
58	Steel Cable	1
61	Seat	1
63	Mesh Seat Back	1
64	Handgrip Foam	2
65	3/8" × 53mm_Carriage Bolt	2
66	1/4" × 3/4" Hex Head Bolt	8
67	3/8" × UNC16 × 4" Hex Head Bolt	2
68	5/16" × UNC18 × 5/8" Hex Head Bolt	9
69	5/16" × 2-1/2" Hex Head Bolt	1
70	5/16" × UNC18 × 1-1/4" Hex Head Bolt	1
71	3/8" × 1-3/4" Hex Head Bolt	4
72	Ø1/4" × 13 × 1T_Flat Washer	12
73	Ø1/4" × 19 × 1.5T_Flat Washer	4
75	Ø17 × Ø23.5 × 1T_Flat Washer	1
76	Ø5/16" × Ø18 × 1.5T_Flat Washer	10
77	Ø3/8" × Ø19 × 1.5T_Flat Washer	4
79	Ø8 × Ø18 × 3T_Knurled Lock Washer	4
80	Ø1/4" Split Washer	7
82	5/16" × 1.5T_Split Washer	9
83	Ø5/16" × 19 × 1.5T_Curved Washer	2
84	Ø3/8" × Ø25 × 2T_Flat Washer	2

<b>Key</b>	<b>Part Description</b>	<b>Q'ty</b>
<b>85</b>	Ø17_C Ring	1
<b>86</b>	Ø20_C Ring	2
<b>87</b>	M8 × 170mm_J Bolt	1
<b>88</b>	M8 × 7T_Nylon Nut	5
<b>89</b>	3/8" × 7T_Nylon Nut	6
<b>90</b>	1/4" × 8T_Nylon Nut	4
<b>91</b>	5/16" × 6T_Nylon Nut	7
<b>93</b>	M6 × 38mm_Socket Head Cap Bolt	1
<b>94</b>	5/16" × UNC18 × 3/4" Hex Head Bolt	6
<b>95</b>	M5 × 12mm_Flat Head Socket Screw	10
<b>97</b>	3 × 20mm_Tapping Screw	4
<b>98</b>	M6 × 15mm_Phillips Head Screw	11
<b>99</b>	M5 × 12mm_Phillips Head Screw	18
<b>101</b>	Ø5 × 16mm_Tapping Screw	10
<b>102</b>	5 × 19mm_Tapping Screw	2
<b>103</b>	Ø3.5 × 16mm_Sheet Metal Screw	12
<b>104</b>	Spring	1
<b>105</b>	4 × 16mm_Sheet Metal Screw	4
<b>106</b>	5/16" × UNC18 × 1- 3/4" Button Head Socket Bolt	2
<b>108</b>	M10 × P1.25 × 10T_Nut	2
<b>111</b>	M5 × P0.8 × 10L_Flat Phillips Head Screw	8
<b>112</b>	12/14mm_Wrench	1
<b>113</b>	13/15mm_Wrench	1
<b>114</b>	Phillips Head Screw Driver	1
<b>116</b>	Pedal (L.R)	1
<b>125</b>	Seat Carriage Cover	1
<b>126</b>	HGP Wire Grommet	1
<b>129</b>	M6 × 6T_Nylon Nut	1
<b>130</b>	13/14mm_Wrench	1
<b>139</b>	Fixing Plate	1
<b>141</b>	Handle Bar Cover	1
<b>143</b>	Seat Track Fixing Plate	1
<b>144</b>	Handgrip End Cap	2
<b>145</b>	Resistance Button W/Cable	2
<b>146</b>	Handgrip Resistance Label (UP)	1
<b>147</b>	Handgrip Resistance Label (DOWN)	1
<b>148</b>	2300mm_Switch Cable (Upper)	1
<b>149</b>	300mm_Handle Switch Bracket	1
<b>150</b>	180mm_Resistance Connecting Cable	1
<b>151</b>	Switch Cable (Lower)	1
<b>153</b>	Console Holder Assembly	1
<b>154</b>	5/16" × 2-1/2" Hex Head Bolt	1
<b>155</b>	Tablet Holder Assembly	1
<b>156</b>	2.3 × 6mm_Sheet Metal Screw	2
<b>157</b>	Pad	1



<b>Key</b>	<b>Part Description</b>	<b>Q'ty</b>
<b>158</b>	Rotate Axle Bracket	1
<b>160</b>	Ø5/16" × 16 × 1.5T Flat Washer	8
<b>161</b>	M6 × 10L Flat Phillips Head Screw	4
<b>162</b>	Ø1/4" × Ø16 × 1.0T Flat Washer	4
<b>163</b>	Sleeve	4
<b>164</b>	M6 × 19L Nut	4
<b>165</b>	M6 × 10L Button Head Socket Bolt	4
<b>166</b>	PU Wheel	4
<b>167</b>	Seat Front/Aft Adjustment Lever	1
<b>168</b>	Lever Anchor	1
<b>169</b>	M5 × 25mm Flat Head Socket Screw	2
<b>170</b>	Ø15 × Ø6 × 4T Nylon Washer	1
<b>171</b>	M5 × 45mm Socket Head Cap Bolt	1
<b>172</b>	Ø5 × Ø10 × 1.0T Flat Washer	1
<b>173</b>	M5 × 5T Nylon Nut	2
<b>177</b>	Rubber Foot Pad	1
<b>184</b>	Flat Washer	2
<b>185</b>	3/8" × 4T Nut	1
<b>186</b>	ChenChin Torsion-Spring	1
<b>187</b>	M5 × 20L Phillips Head Screw	1
<b>188</b>	5/16" × UNC18 × 1-1/2" Hex Head Bolt	1
<b>189</b>	Rubber Pad	2
<b>190</b>	Tablet Holder Front Cover	1
<b>190-1</b>	Tablet Holder Rear Cover	1
<b>190-2</b>	Tablet Holder Top clip	1
<b>190-3</b>	Tablet Holder Bottom clip	1
<b>190-4</b>	Spring	2
<b>190-5</b>	Spring column	2
<b>191</b>	3/8" × UNC16 × 12.5T Cap Nut	2
<b>192</b>	3.5 × 12mm Sheet Metal Screw	7

# MANUFACTURER'S LIMITED WARRANTY

Dyaco Canada Inc. warrants all its bike parts for the period of time listed below, from the date of retail sale, as determined by a sales receipt. Dyaco Canada Inc.'s responsibilities include providing new or remanufactured parts at Dyaco Canada Inc.'s option and technical support to our independent dealers and service organizations. In the absence of a dealer or service organization, these warranties will be administered by Dyaco Canada Inc. directly to a consumer. The warranty period applies to the following components:

<b>Light Commercial</b> (5 Hour use or less in a non-dues paying facility)		<b>Residential</b>	
Parts	3 Years	Parts	10 Years
Frame	Lifetime	Frame	Lifetime
Brake	5 Years	Brake	Lifetime
Labour	1 Year	Labour	1 Year

This warranty is not transferable and is extended only to the original owner.

The warranty shall not apply to exercise units which are (1) used for commercial or other income-producing purposes or (2) subject to misuse, neglect, accident or unauthorized repair and alterations.

This warranty provided herein is in lieu of all other express warranties; any implied warranties, including any implied warranties of merchantability or fitness for a particular purpose, are limited in duration to the first 12 months from the date of purchase. All other obligations or liabilities, including liability for consequential damages, are hereby excluded.

## REPAIR PARTS AND SERVICE

All of the parts for the Spirit cycle shown in this manual can be ordered from Dyaco Canada Inc. 5955 Don Murie Street, Niagara Falls, Ontario L2G 0A9. When ordering parts, the parts will be sent and billed at the current prices. Prices may be subject to change without notice.

A Credit Card, Cheque, or Money Order must accompany all orders. Standard hardware items are available at your local hardware store.

To ensure prompt and correct handling of any errors, or to answer any questions, please call our Toll Free number: 1-888-707-1880, or local number 1-905-353-8955 or fax 1-905-353-8968, email [customerservice@dyaco.ca](mailto:customerservice@dyaco.ca) or visit our website at [www.dyaco.ca](http://www.dyaco.ca). Office hours are from 8:30 AM to 5:00 PM Monday to Friday Eastern Standard Time.

Always include the following information when ordering parts

- Model number
- Name of each part
- Part number of each part

# dyaco

Please visit us online for information about our other brands and products manufactured and distributed by Dyaco Canada Inc.

**SPIRIT**

[spiritfitness.ca](http://spiritfitness.ca)

**XTEERRA**

[xterrafitness.ca](http://xterrafitness.ca)

**UFC**

[dyaco.ca/UFC/UFC-home.html](http://dyaco.ca/UFC/UFC-home.html)

**SOLE**  
FITNESS

[solefitness.ca](http://solefitness.ca)

**EVERLAST**

[dyaco.ca/products/everlast.html](http://dyaco.ca/products/everlast.html)

 *Johnny G*  
by **SPIRIT**

[spiritfitness.ca/johnnyg.html](http://spiritfitness.ca/johnnyg.html)

**TRAINOR**  
**SPORTS**

[trainorsports.ca](http://trainorsports.ca)

For more information, please contact Dyaco Canada Inc.  
T: 1-888-707-1880 | 5955 Don Murie St., Niagara Falls, Ontario L2G 0A9 | [sales@dyaco.ca](mailto:sales@dyaco.ca)

Dyaco Canada Inc. [dyaco.ca](http://dyaco.ca)